



Martin-**Flex** couplings provide all the desirable features of an ideal flexible coupling, including Taper Bush fixing. The Martin-**Flex** coupling is a "torsionally elastic" coupling offering versatility to designers and engineers with a choice of flange combinations to suit most applications.

The flanges are available in either F (face) or H (hub) Taper Bush fitting or bored to size .

With the addition of a spacer flange the coupling can be used to accommodate standard distance between shaft ends and facilitate pump maintenance.

Martin-**Flex** couplings can accommodate simultaneous maximum misalignment in all planes without imposing undue loads on adjacent bearings and the excellent shock-absorbing properties of the flexible tyre reduce vibration and torsional oscillation

Martin-**Flex** tyres are available in natural rubber compounds for use in ambient temperatures between -50°C and +50°C . Chloroprene rubber compounds are available for use in adverse operating conditions (e.g. oil or grease contamination) and can be used in temperatures of -15°C to +70°C. The chloroprene component should also be used when fire-resistance and anti-static (F.R.A.S.) properties are required.

SELECTION

1. Service Factor

Determine the required Service Factor from table below.

2. Design Power

Multiply the normal running power by the service factor. This gives the design power which is used as a basis for selecting the coupling.

3. Coupling Size

Refer to Power Ratings table page C-7 and from the appropriate speed read across until a power greater than that required in step (b) is found.

The size of Martin-**Flex** coupling required is given at the head of that column.

4. Bore Size

Check for Dimensions table page C-9, C-10 that chosen flanges can accommodate required bores.

EXAMPLE

A Martin-**Flex** coupling is required to transmit 50kW from an A.C. electric motor which runs at 1440 rev/min to a rotary screen for 10 hours per day. The motor shaft is 60mm diameter and the screen shaft is 55mm diameter. Taper Bush is required.

1. Service Factor

The appropriate service factor is 1,3.

2. Design Power

Design Power = 50 x 1,3 = 65kW.

3. Coupling Size

By reading across from 1440 rev/min in the power ratings table the first power figure to exceed the required 65kW in step(b) is 75,4kW. The size of coupling is F90 Martin-**Flex**.

4. Bore Size

By referring to the dimensions table it can be seen that both shaft diameters fall within the bore range available.

SERVICE FACTORS

SPECIAL CASES For applications where substantial shock, vibration and torque fluctuations occur, and for reciprocating machines (e.g. internal combustion engines, piston pumps and compressors) refer to Martin with full machine details for analysis.	Type of Driven Unit					
	Electric Motors Steam Turbines			Internal Combustion Engines Steam Engines Water Turbines		
	Hours per day duty			Hours per day duty		
Type of Driven Machine	10 and under	over 10 to 16 incl.	over 16	10 and under	over 10 to 16 incl.	over 16
CLASS 1 Agitators, Brewing machinery, Centrifugal compressors and pumps. Belt conveyors, Dynamometers, Lineshafts, Fans up to 7,5kW. Blowers and exhausters (except positive displacement), Generators.	0,8	0,9	1,0	1,3	1,4	1,5
CLASS 2* Clay working machinery, General machine tools, paper mill beaters and winders, Rotary pumps, Rubber extruders, Rotary screens, Textile machinery, Marine propellers and Fans over 7,5kw.	1,3	1,4	1,5	1,8	1,9	2,0
CLASS 3* Bucket elevators, Cooling tower fans, Piston compressors and pumps, Foundry machinery, Metal presses, Paper mill calendars Hammer mills, Presses and pulp grinders, Rubber calendars, Pulverizers and Positive displacement blowers.	1,8	1,9	2,0	2,3	2,4	2,5
CLASS 4* Reciprocating conveyors, Gyrotory crushers, Mills (ball, pebble and rod), Rubber machinery (Banbury mixers and mills) and Vibratory screens.	2,3	2,4	2,5	2,8	2,9	3,0

*It is recommended that keys (with top clearance if in Taper bushes) are fitted on application where load function is expected.

+ Couplings for use with internal combustion engines may require special consideration, such as a flywheel configuration. Consult Martin for specifications.



POWER RATINGS (kW)

Speed rev/min	Coupling Size														
	F40	F50	F60	F70	F80	F90	F100	F110	F120	F140	F160	F180	F200	F220	F250
100	0,25	0,69	1,33	2,62	3,93	5,24	7,07	9,16	13,9	24,3	39,5	65,7	97,6	121	154
200	0,50	1,38	2,66	5,24	7,85	10,5	14,1	18,3	27,9	48,7	79,0	131	195	243	307
300	0,75	2,07	3,99	7,85	11,8	15,7	21,2	27,5	41,8	73,0	118	197	293	364	461
400	1,01	2,76	5,32	10,5	15,7	20,9	28,3	36,6	55,7	97,4	158	263	391	486	615
500	1,26	3,46	6,65	13,1	19,6	26,2	35,3	45,8	69,6	122	197	328	488	607	768
600	1,51	4,15	7,98	15,7	23,6	31,4	42,4	55,0	83,6	146	237	394	586	729	922
700	1,76	4,84	9,31	18,3	27,5	36,6	49,5	64,1	97,5	170	276	460	684	850	1076
720	1,81	4,98	9,57	18,8	28,3	37,7	50,9	66,0	100	175	284	473	703	875	1106
800	2,01	5,53	10,6	20,9	31,4	41,9	56,5	73,3	111	195	316	525	781	972	1229
900	2,26	6,22	12,0	23,6	35,3	47,1	63,6	82,5	125	219	355	591	879	1093	1383
960	2,41	6,63	12,8	25,1	37,7	50,3	67,9	88,0	134	234	379	630	937	1166	1475
1000	2,51	6,91	13,3	26,2	39,3	52,4	70,7	91,6	139	243	395	657	976	1215	1537
1200	3,02	8,29	16,0	31,4	47,1	62,8	84,9	110	167	292	474	788	1172		
1400	3,52	9,68	18,6	36,6	55,0	73,3	99,0	128	195	341	553	919			
1440	3,62	9,95	19,1	37,7	56,5	75,4	102	132	201	351	568	945			
1600	4,02	11,1	21,3	41,9	62,8	83,8	113	147	223	390					
1800	4,52	12,4	23,9	47,1	70,7	94,2	127	165	251	438					
2000	5,03	13,8	26,6	52,4	78,5	105,5	141	183	279						
2200	5,53	15,2	29,3	57,6	86,4	115	155	202							
2400	6,03	16,6	31,9	62,8	94,2	126	170								
2600	6,53	18,0	34,6	68,1	102	136	184								
2800	7,04	19,4	37,2	73,3	110	147									
2880	7,24	19,9	38,3	75,4	113	151									
3000	7,54	20,7	39,9	78,5	118	157									
3600	9,05	24,9	47,9	94,2											

The figures in heavier type are for standard motor speeds. All these power ratings are calculated at constant torque. For speeds below 100 rev/min and intermediate speeds use nominal torque ratings.

PHYSICAL CHARACTERISTICS - FLEXIBLE TYRES

Characteristics	Coupling Size														
	F40	F50	F60	F70	F80	F90	F100	F110	F120	F140	F160	F180	F200	F220	F250
Maximum speed rev/min	4500	4500	4000	3600	3100	3000	2600	2300	2050	1800	1600	1500	1300	1100	1000
Nominal Torque Nm TKN	24	66	127	250	375	500	675	875	1330	2325	3770	6270	9325	11600	14675
Maximum Torque Nm TK MAX	64	160	318	487	759	1096	1517	2137	3547	5642	9339	16455	23508	33125	42740
Torsional Stiffness Nm/°	5	13	26	41	63	91	126	178	296	470	778	1371	1959	2760	3562
Max. parallel misalignment mm	1,1	1,3	1,6	1,9	2,1	2,4	2,6	2,9	3,2	3,7	4,2	4,8	5,3	5,8	6,6
Maximum end float mm	1,3	1,7	2,0	2,3	2,6	3,0	3,3	3,7	4,0	4,6	5,3	6,0	6,6	7,3	8,2
Approximate mass, kg	0,1	0,3	0,5	0,7	1,0	1,1	1,1	1,4	2,3	2,6	3,4	7,7	8,0	10	15
Alternating Torque Nm @ 10Hz TKW	11	26	53	81	127	183	252	356	591	940	1556	2742	3918	5521	7124
Resonance Factor V	7	7	7	7	7	7	7	7	7	7	7	7	7	7	7
Damping Coefficient	0,9	0,9	0,9	0,9	0,9	0,9	0,9	0,9	0,9	0,9	0,9	0,9	0,9	0,9	0,9

Maximum torque figures should be regarded as short duration overload ratings for use in such circumstances as direct-on-line starting.
All flexible tyres have an angular misalignment capacity up to 4°

FLEXIBLE TYRE CODE NUMBERS

Unless otherwise specified Martin Flexible tyres will be supplied in a natural rubber compound which is suitable for operation in temperatures -50°C to +50°C.

A chloroprene compound is available which is Fire Resistant and Anti-Static (F.R.A.S.) and has greater resistance to heat and oil.

This is suitable for operation in temperatures -15°C to +70°C. For temperatures outside these ranges - consult Martin.

Tyre Part Numbers		
Size	Natural	F.R.A.S.
F40	F40NA	F40FR
F50	F50NA	F50FR
F60	F60NA	F60FR
F70	F70NA	F70FR
F80	F80NA	F80FR
F90	F90NA	F90FR
F100	F100NA	F100FR
F110	F110NA	F110FR
F120	F120NA	F120FR
F140	F140NA	F140FR
F160	F160NA	F160FR
F180	F180NA	F180FR
F200	F200NA	F200FR
F220	F220NA	F220FR
F250	F250NA	F250FR

BACK STOP/SAFETY DOGS

POSITIVE DRIVE APPLICATIONS

In the unlikely event of the failure of the flexible tyre, the drive can be maintained with the interaction of fitted back stop/safety dogs.

Safety dogs are available for coupling sizes F70 to F250 and should be fitted when it is essential to avoid run back, e.g. cranes, hoists, lifts, elevators, inclined conveyors, etc. Consult local Martin distributor for details.

**Whatever Your Need For Couplings
Martin Has Them**

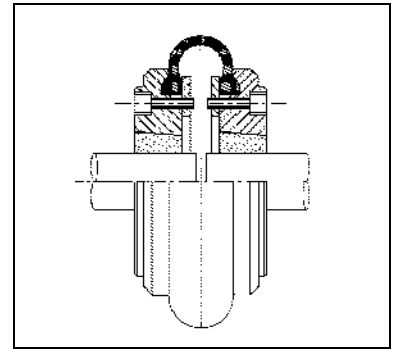
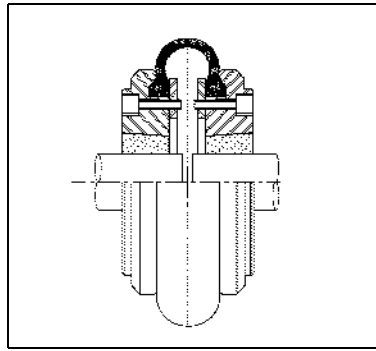
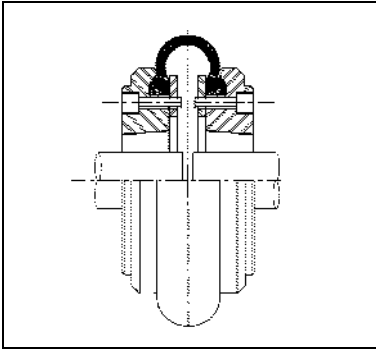

SIZES F40-60

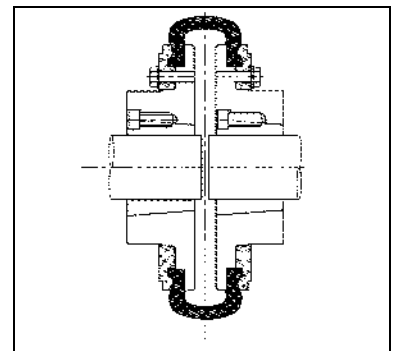
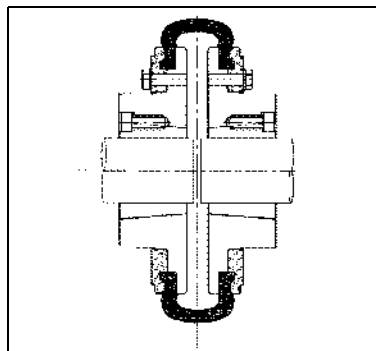
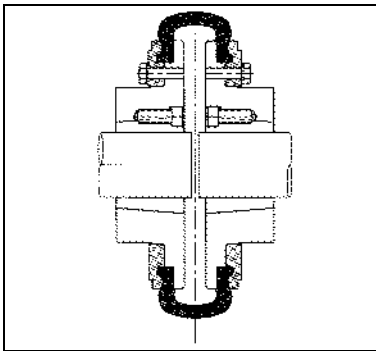

SIZES F70-250

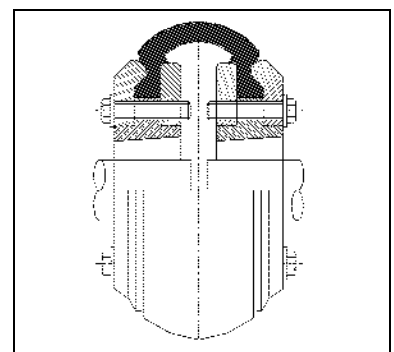
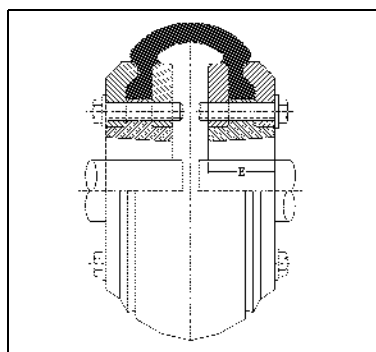
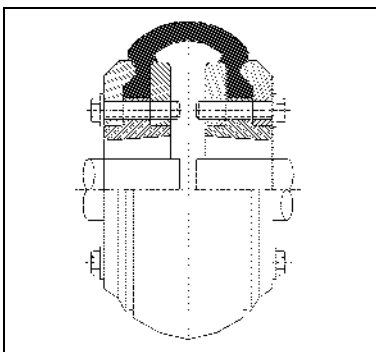

**SIZES F70-120
(Reversible)**



Martin-Flex® Couplings - Dimensions

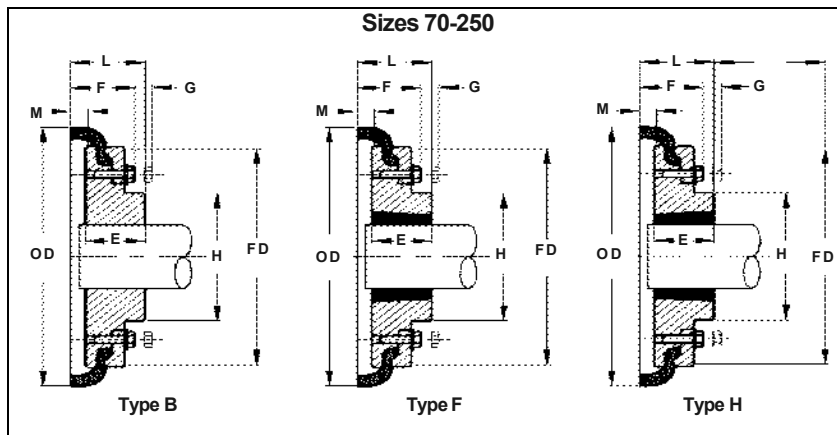
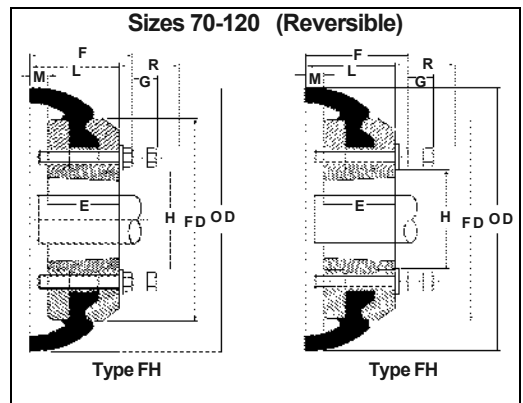
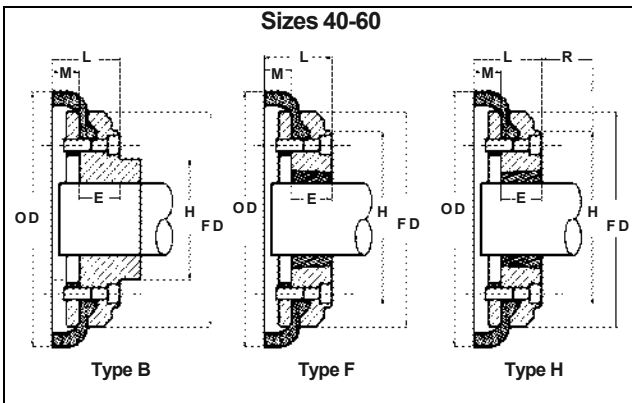

DIMENSIONS OF Martin - FLEX FLANGES TYPES B, F, H & FH

Part Number	Size	Type	Bush No.	Max. Bore (B) Metric	Types F & H			Type B		Screw over Key	O.D.	FD	H	F	G*	M*	Mass* (kg)	Inertia* (kgm2)
					L	E	R*	L	E									
F40B	F40	B	—	30	—	—	29	33	22	M5	104	82	—	—	—	11	0,8	,0007
F40F	F40	F	1008	25	33	22	29	—	—	—	104	82	—	—	—	11	0,8	4
F40H	F40	H	1008	25	33	22	29	—	—	—	104	82	—	—	—	11	0,8	,0007
F50B	F50	B	—	38	—	—	38	45	32	M5	133	100	79	—	—	12,5	1,2	4
F50F	F50	F	1210	32	37,5	25	38	—	—	—	133	100	79	—	—	12,5	1,2	,0007
F50H	F50	H	1210	32	37,5	25	38	—	—	—	133	100	79	—	—	12,5	1,2	4
F60B	F60	B	—	45	—	—	38	55	38	M6	165	125	70	—	—	16,5	2,0	,0011
F60F	F60	F	1610	42	41,5	25	38	—	—	—	165	125	103	—	—	16,5	2,0	5
F60H	F60	H	1610	42	41,5	25	38	—	—	—	165	125	103	—	—	16,5	2,0	,0011
F70B	F70	B	—	50	—	—	—	47	35	M10	187	142	80	50	13	11,5	3,1	5
F70F	F70	F	2012	50	43,5	32	42	—	—	—	187	142	80	50	13	11,5	3,1	,0011
F70H	F70	H	1610	42	36,5	25	38	—	—	—	187	142	80	50	13	11,5	3,0	5
F70FH	F70	FH	1610	42	37	25	42	—	—	M8	187	142	80	44,25	13	11,5	—	—
F80B	F80	B	—	63	—	—	—	55	42	M10	211	165	98	54	16	12,5	4,9	,0052
F80F	F80	F	2517	60	57,5	45	48	—	—	—	211	165	97	54	16	12,5	4,9	,0052
F80H	F80	H	2012	50	44,5	32	32	—	—	—	211	165	98	54	16	12,5	4,6	,0052
F80FH	F80	FH	2012	50	45,5	32	48	—	—	M8	211	165	98	52,75	16	12,5	—	—
F90B	F90	B	—	75	—	—	—	62,5	49	M12	235	187	112	60	16	13,5	7,1	0,009
F90F	F90	F	2517	60	58,5	45	48	—	—	—	235	187	108	60	16	13,5	7,0	0,009
F90H	F90	H	2517	60	58,5	45	48	—	—	—	235	187	108	60	16	13,5	7,0	0,009
F90FH	F90	FH	2517	60	58,5	45	48	—	—	M10	235	187	112	67,86	16	13,5	—	—
F100B	F100	B	—	80	—	—	—	69,5	56	M12	254	214	125	62	16	13,5	9,9	0,018
F100F	F100	F	3020	75	64,5	51	55	—	—	—	254	214	120	62	16	13,5	9,9	0,018
F100H	F100	H	2517	60	58,5	45	48	—	—	—	254	214	113	62	16	13,5	9,4	0,017
F100FH	F100	FH	2517	60	59,5	45	55	—	—	M10	254	214	125	68,86	16	13,5	—	—

Dimensions in millimeters unless otherwise specified.

* G is the amount by which clamping screws need to be withdrawn to release tyre.

J is the wrench clearance to allow for tightening/loosening the bush on the shaft and the clamping screws on sizes F40, F50 and F60. The use of a shortened wrench will allow this dimension to be reduced.

* M is half the distance between flanges, Shaft ends, although normally located twice M apart, can protect beyond the flanges as shown. In this event allow sufficient space between for end float and misalignment.

Mass and inertia figures are for single flange with mid range bore and included clamping ring, screws and washers and half tyre.

For pilot bore 'B' flange code is listed.

Flanges are also available finish bored with keyway if required.

Bore must be specified on order.

#Note: On sizes F70, 80, 100 and 120 the 'F' direction bush is larger than that in the 'H' direction

Martin-Flex® Couplings - Dimensions

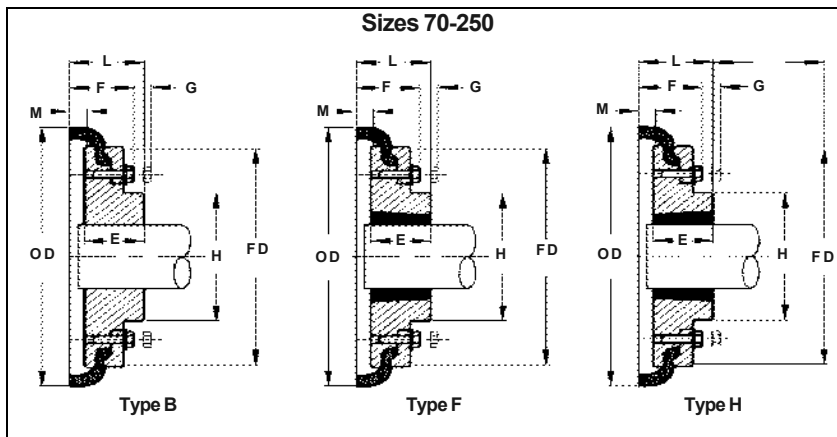
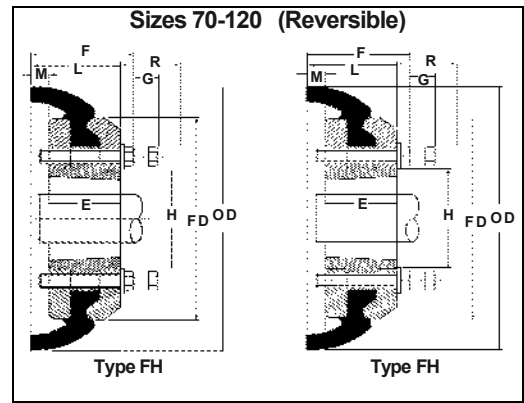
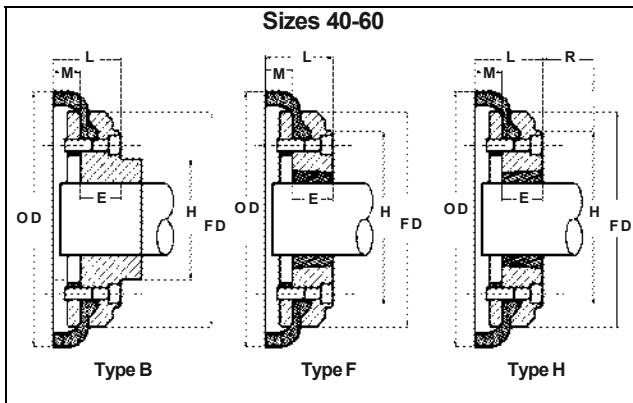

DIMENSIONS OF Martin - FLEX FLANGES TYPES B, F, H & FH

Part Number	Size	Type	Bush No.	Max. Bore (B) Metric	Types F & H			Type B		Screw over Key	O.D.	FD	H	F	G*	M*	Mass* (kg)	Inertia* (kgm2)
					L	E	R*	L	E									
F110B	F110	B	—	90	—	—	—	75,5	63	M12	279	232	128	62	16	12,5	12,5	0,032
F110F	F110	F	3020	75	63,5	51	55	—	—	—	279	232	134	62	16	12,5	11,7	0,031
F110H	F110	H	3020	75	63,5	51	55	—	—	—	279	232	134	62	16	12,5	11,7	0,031
F110FH	F110	FH	3020	75	64,5	51	55	—	—	M10	279	232	134	73,68	16	12,5	—	—
F120B	F120	B	—	100	—	—	—	84,5	70	M16	314	262	143	67	16	14,5	16,9	0,055
F120F	F120	F	3525	100	79,5	65	67	—	—	—	314	262	140	67	16	14,5	16,5	0,055
F120H	F120	H	3020	75	65,5	51	55	—	—	—	314	262	140	67	16	14,5	15,9	0,054
F120FH	F120	FH	3020	75	66,5	51	67	—	—	M12	314	262	140	77,18	16	14,5	—	—
F140B	F140	B	—	125	—	—	—	110,5	94	M20	359	312,5	180	73	17	16	22,2	0,081
F140F	F140	F	3525	100	81	65	67	—	—	—	359	312,5	180	73	17	16	22,3	0,078
F140H	F140	H	3525	100	81	65	67	—	—	—	359	312,5	180	73	17	16	22,3	0,078
F160B	F160	B	—	140	—	—	—	117	102	M20	402	348	197	78	19	15	35,8	0,137
F160F	F160	F	4030	115	91	76	80	—	—	—	402	348	197	78	19	15	32,5	0,137
F160H	F160	H	4030	115	91	76	80	—	—	—	402	348	197	78	19	15	32,5	0,130
F180B	F180	B	—	150	—	—	—	137	114	M20	470	396	205	94	19	23	49,1	0,254
F180F	F180	F	4535	125	112	89	89	—	—	—	470	396	205	94	19	23	42,2	0,255
F180H	F180	H	4535	125	112	89	89	—	—	—	470	396	205	94	19	23	42,2	0,255
F200B	F200	B	—	150	—	—	—	138	114	M20	508	432	205	103	19	24	58,2	0,469
F200F	F200	F	4535	125	113	89	89	—	—	—	508	432	205	103	19	24	53,6	0,380
F200H	F200	H	4535	125	113	89	89	—	—	—	508	432	205	103	19	24	53,6	0,380
F220B	F220	B	—	160	—	—	—	154,5	127	M20	562	472	224	118	20	27,5	79,6	0,871
F220F	F220	F	5040	125	129,5	102	92	—	—	—	562	472	224	118	20	27,5	72,0	0,847
F220H	F220	H	5040	125	129,5	102	92	—	—	—	562	472	224	118	20	27,5	72,0	0,847
F250B	F250	B	—	190	—	—	—	161,5	132	M20	628	532	254	125	25	29,5	104,0	1,301

Dimensions in millimeters unless otherwise specified.

* G is the amount by which clamping screws need to be withdrawn to release tyre

J is the wrench clearance to allow for tightening/loosening the bush on the shaft and the clamping screws on sizes F40, F50 and F60. The use of a shortened wrench will allow this dimension to be reduced.

* M is half the distance between flanges, Shaft ends, although normally located twice M apart, can protect beyond the flanges as shown. In this event allow sufficient space between for end float and misalignment.

Mass and inertia figures are for single flange with mid range bore and included clamping ring, screws and washers and half tyre.

For pilot bore 'B' flange code is listed.

Flanges are also available finish bored with keyway if required.

Bore must be specified on order.

#Note: On sizes F70, 80, 100 and 120 the 'F' direction bush is larger than that in the 'H' direction.



Martin-Flex® Spacer Couplings

Comprising a Martin-Flex coupling size (F40-F140) complete with a spacer flange designed for use on applications where it is an advantage to be able to move either shaft axially without disturbing the driving or driven machine (e.g. centrifugal pump rotors), Martin-Flex spacer couplings are primarily designed for standard distance between shaft and dimensions 100, 140 and 180mm.

SELECTION

1. Select a suitable size of Martin-Flex coupling using method shown on page C-6. Read down the first column in table below and locate the size of coupling desired.
2. Read across until the required distance between shaft ends can be accommodated.

3. Note the required spacer coupling designation at head of column.
4. Check from the Spacer Coupling Dimensions table below that the selected spacer/coupling combination can accommodate the machine shaft size.

DISTANCE BETWEEN SHAFT ENDS

Size	Distance between Shaft Ends (MM)																			
	SM12		S M16				SM25						SM30				SM35			
	80(100)		100		140		100		140		180		140		180		140		180	
	Min	Max	Min	Max	Min	Max	Min	Max	Min	Max	Min	Max	Min	Max	Min	Max	Min	Max	Min	Max
F40	80	100	100	113	140	150														
F50			100	116	140	156														
F60			100	124	140	164														
F70							100	114	140	154	180	194								
F80							100	117	140	157	180	197								
F90									140	158	180	198								
F100													140	158	180	198				
F110													140	156	180	196				
F120																	140	160	180	200
F140																	140	163	180	203

Note: Alternative distances between shaft ends may be accommodated. Consult Martin.

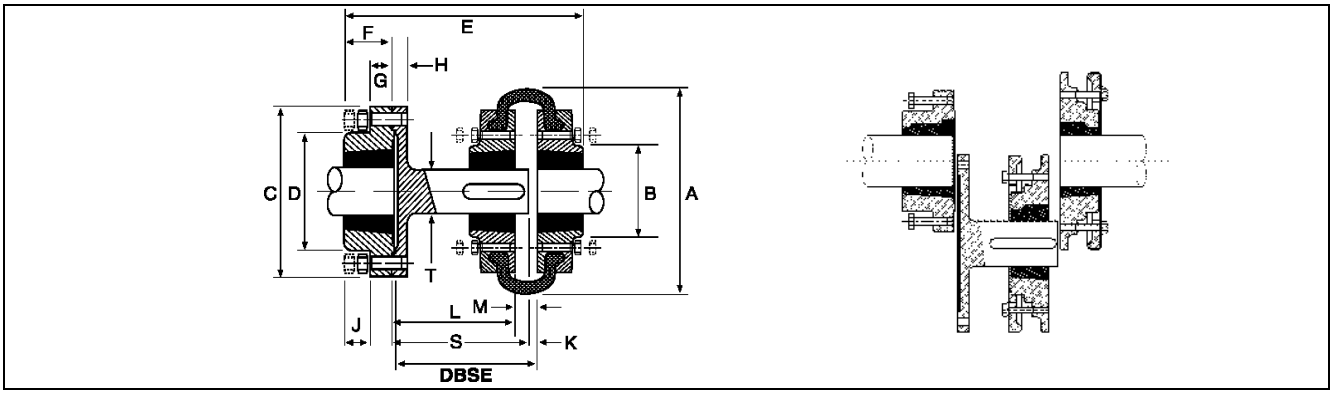

SPACER COUPLING DIMENSIONS

Spacer	Nom DBSE	Martin-Flex	Spacer Bush Size	Max. Bore		Martin-Flex Bush Size	Max. Bore		A	B	C	D	E	F	G	H	J	K	L	M	S	T	
				mm	Inch		mm	Inch															
SM12	80	F40	1210	32	1,250	1008	25	1	104	82	118	83	134	25	14	15	14	6	65	22	77	25	25
SM12	100	F40	1210	32	1,250	1008	25	1	104	82	118	83	140	25	14	15	14	22	77	22	77	25	25
SM16	100	F40	1615	42	1,625	1008	25	1	104	82	127	80	157	38	18	15	14	9	88	22	94	32	32
SM16	140	F40	1615	42	1,625	1008	25	1	104	82	127	80	187	38	18	15	14	9	128	22	134	32	32
SM16	100	F50	1615	42	1,625	1210	32	1,250	133	79	127	80	160	38	18	15	14	9	85	25	94	32	32
SM16	140	F50	1615	42	1,625	1210	32	1,250	133	79	127	80	200	38	18	15	14	9	125	25	134	32	32
SM16	100	F60	1615	42	1,625	1610	42	1,625	165	103	127	80	161	38	18	15	14	9	78	33	94	32	32
SM16	140	F60	1615	42	1,625	1610	42	1,625	165	103	127	80	201	38	18	15	14	9	118	33	134	32	32
SM25	100	F70	2517	60	2,50	2012	50	2	187	80	178	123	180	45	22	16	14	9	80	23	94	48	48
SM25	140	F70	2517	60	2,50	2012	50	2	187	80	178	123	220	45	22	16	14	9	120	23	174	48	48
SM25	180	F70	2517	60	2,50	2012	50	2	187	80	178	123	260	45	22	16	14	9	160	23	174	48	48
SM25	100	F80	2517	60	2,50	2517	60	2,50	211	95	178	123	193	45	22	16	14	9	78	25	94	48	48
SM25	140	F80	2517	60	2,50	2517	60	2,50	211	95	178	123	233	45	22	16	14	9	118	25	134	48	48
SM25	180	F80	2517	60	2,50	2517	60	2,50	211	95	178	123	273	45	22	16	14	9	158	25	174	48	48
SM25	140	F90	2517	60	2,50	2517	60	2,50	235	108	178	123	233	45	22	16	14	9	116	27	134	48	48
SM25	180	F90	2517	60	2,50	2517	60	2,50	235	108	178	123	273	45	22	16	14	9	156	27	174	48	48
SM30	140	F100	3020	75	3	3020	75	3	254	120	216	146	245	51	29	20	17	9	116	27	134	60	60
SM30	180	F100	3020	75	3	3020	75	3	254	120	216	146	285	51	29	20	17	9	156	27	174	60	60
SM30	140	F110	3020	75	3	3020	75	3	279	134	216	146	245	51	29	20	17	9	118	25	134	60	60
SM30	180	F110	3020	75	3	3020	75	3	279	134	216	146	285	51	29	20	17	9	158	25	174	60	60
SM35	140	F120	3525	100	4	3525	100	4	314	140	248	178	272	63	34	20	17	9	114	29	134	80	80
SM35	180	F120	3525	100	4	3525	100	4	314	140	248	178	312	63	34	20	17	9	154	29	174	80	80
SM35	140	F140	3525	100	4	3525	100	4	359	178	248	178	271	63	34	20	17	9	111	27	134	80	80
SM35	180	F140	3525	100	4	3525	100	4	359	178	248	178	312	63	34	20	17	9	151	27	174	80	80

Note: Larger sizes of spacer couplings are available. Consult Martin.

* F40 'B' Flange must be used to fit spacer shaft.
 'F' Flange must be used to fit spacer shaft.
 DBSE- distance between shaft ends.

Martin-Flex® Couplings Installation Instructions



NOTE: Satisfactory performance depends on correct installation and maintenance. Under no circumstances should any machine be started unless the coupling and associated machine is completely assembled. All instructions in this manual should therefore be followed accurately.

1. Thoroughly clean all components, paying particular attention to the removal of the protective coating in flange bores and on bushes.
2. Fit flanges to the shafts after placing the external clamping rings on the shafts. (Where Taper flanges are used, see separate fitting instructions supplied with the Taper Bushes.) Locate flanges so that dimension M is obtained (see paragraph 3). Flanges with internal clamping rings should then have the clamping rings fitted, engaging only two or three of the threads of the screws at this time.
3. Bring shafts into line until dimension M is obtained (table 2). If shaft end float is to occur, locate the shafts at mid-position of end float when checking dimension M. Note the shafts ends may project beyond the faces of the flanges if required. In this event, allow sufficient space between shaft ends for end float and mis-alignment. Flanges should be fitted flush with the end of the shaft when used with Mill-Motor flanges.
4. Check parallel alignment by laying a straight edge across the flanges at several positions around the circumference. Check angular alignment by measuring gap between flanges at several positions around the circumference. It is desirable to align the coupling as accurately as possible, particularly on high speed applications.

5. Open out tyre and fit over coupling flanges ensuring that the tyre beads seat properly on the flanges and/or clamping rings. To ensure proper seating, it may be necessary to strike the outside diameter of the tyre with a small mallet. When seated there should be a gap between the ends of the tyre as shown in Table 1.

TABLE 1

Coupling Size	F40 to F60	F70 to F120	F140 and F160	F180 to F250
Tyre Gap mm	2	3	5	6

6. Tighten clamping ring screws alternately and evenly (half turn at a time) working round each flange until the required screw torque is achieved (table 2).

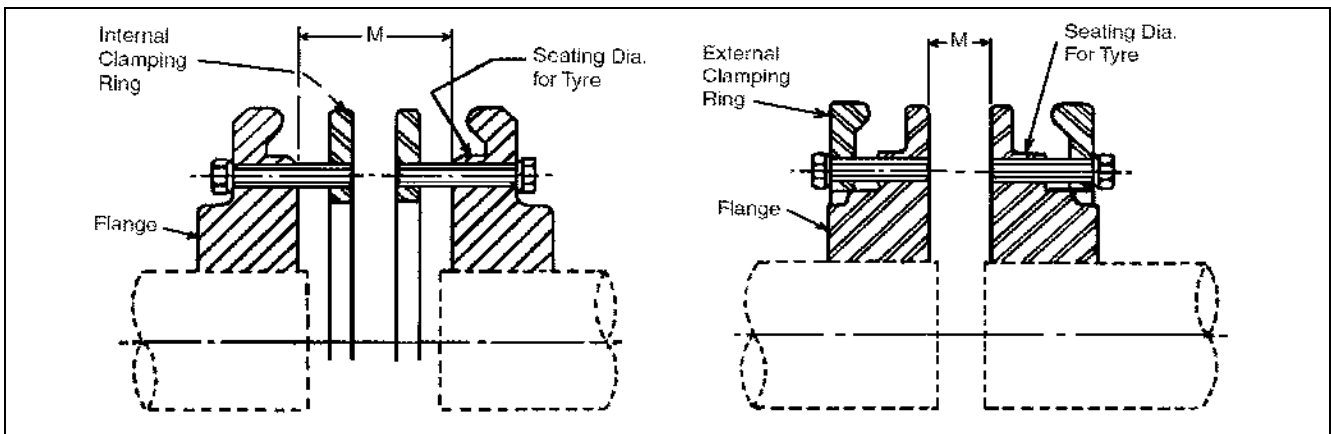

TABLE 2

Coupling Size		F40	F50	F60	F70	F80	F90	F100	F110	F120	F140	F160	F180	F200	F220	F250
M	MM	22	25	33	23	25	27	27	25	29	32	30	46	48	55	59
Screw Size		M6	M6	M6	M8	M8	M10	M10	M10	M12	M12	M16	M16	M16	M20	M20
Clamping Screw Torque	Nm	15	15	15	24	24	40	40	40	50	55	80	105	120	165	165



Martin-Flex® flexible couplings smoothly transmit power while compensating for shaft misalignment to 4°, parallel misalignment to 3,2 and end float to 7,9. The two piece flange design provides quick and easy installation and the elastomeric element absorbs shock and torsional vibration through a wide temperature range

Quick Selection Procedure

1. Select the proper service factor from Chart 1.
2. Determine **Design Kw** by multiplying the **Service Factor** and the **Drive Kw**.
3. Locate the intercept of **Shaft Speed** and **Design Kw** from Chart 2.
4. Order per coupling: (2) bushings, (2) flange assemblies, (1) flexible tire element .

Chart 1 Service Factors

Application	Factor	Application	Factor	Application	Factor	Application	Factor	Application	Factor
AGITATORS		Pump, Screen Drive, Stackler, Utility Winch	1,5	METAL FORMING MACHINES		Hog.....	2,0	Water.....	1,0
Paddle or Propeller (Vert. or Horiz.), Screw.....	1,0	DYNAMOMETER	1,0	Draw Bench Carriage, Main Drive, Extruder,		Roller.....	1,5	SEWAGE DISPOSAL EQUIPMENT	1,0
BREWING AND DISTILLING		ELEVATORS		Wire Drawing, Flattening Machine.....	2,0	PUMPS		Centrifugal.....	1,0
Bottling Machinery, Brew Kettle, Cooker (Cont. Duty), Mash Tub.....	1,0	Bucket, Freight.....	2,0	Oil Well Pumping (not over 150% peak torque)....	2,0	Descaling, Gear Type.....	1,5	SHREDDER	1,5
Scale Hopper —		EXCITER	1,0	MILLS (Rotary Type)		Oil Well Pumping (non-reciprocating —		STEEL INDUSTRY	
Frequent Starting Peaks.....	1,5	FANS		Ball or Pebble Direct or	2,5	1 cyl. — single acting.....	2,5	Cold Mills	
CAN FILLING MACHINE	1,0	Centrifugal.....	1,0	on LS Shaft Gear Reducer... ..	2,5	1 cyl. — double acting.....	2,0	Coiler (up or down).....	1,5
CAR DUMPER	1,5	Cooling Tower	2,0	on HS Shaft Gear Reducer... ..	2,0	2 cyl. — single acting.....	2,0	Strip, Temper	2,0
CAR PULLER	1,5	Large (Mine, etc.).....	1,5	Dryer and Cooler.....	1,5	2 cyl. — double acting.....	1,5	Hot Mills	
CLARIFIER	1,0	Light.....	1,0	Rod or Tube Direct or	2,5	3 cyl. — or more	1,5	Coiler (up or down), Edger Drive	1,5
CLASSIFIER	1,0	Propeller (Indoor).....	1,5	on LS Shaft Gear Reducer... ..	2,5	RUBBER INDUSTRY		Feed Roll (Blooming), Roughing Mill Delivery (non-reversing),	
CLAY-WORKING MACHINES		FOOD INDUSTRY		on HS Shaft Gear Reducer... ..	2,0	Banbury Mixer.....	2,5	Sheet, Strip	3,0
Brick Press, Briquette Machine, Clay Working Machine, Pug Mill.....	1,5	Beet Slicer.....	1,5	Tumbling Barrel.....	1,5	Calender.....	2,0	Rod Mill	2,5
COMPRESSORS		Cereal Cooker.....	1,0	MIXERS		Cracker, Mixing Mill, Plasticator.....	2,5	Soaking Pit Cover Drive.....	3,0
Lobe, Rotary.....	2,0	Dough Mixer, Meat Grinder.....	1,5	Concrete (Continuous or intermittent), Muller-Simpson type	1,5	STEERING GEAR	1,0	STOKER	1,0
Reciprocating** —		GENERATORS		OIL INDUSTRY		Refiner, Sheeter, Tire Building Machine.....	2,0	TEXTILE MILLS	
1 cyl. — single acting.....	3,5	Even Load.....	1,0	Chiller.....	1,0	Tire and Tube Press Opener (Based on Peak Torque)....	1,0	Batcher.....	1,0
1 cyl. — double acting.....	3,0	Hoist or Railway Service	1,5	Oil Well Pumping (not over 150% peak torque)....	2,0	Tuber and Strainer.....	1,5	Calender, Card.....	1,5
2 cyl. — single acting.....	3,0	Welder Load.....	2,0	Paraffin Filter Press.....	1,5	Warming Mill.....	2,0	Machine, Dry Can.....	1,5
2 cyl. — double acting.....	2,5	GRIZZLY	2,0	PAPER MILLS		Dyeing Machinery.....	1,0	Loom.....	1,5
3 cyl. or more — single acting.....	2,5	KILN.....	2,0	Agitator.....	1,0	Washer.....	2,5	Mangel, Napper, Soaper.....	1,0
3 cyl. or more — double acting.....	2,0	LAUNDRY MACHINES		Barking Drum.....	2,5	SCREENS		Spinner, Tenter Frame.....	1,5
CONVEYORS		Tumbler, Washer.....	2,0	Beater and Pulper.....	1,5	Air Washing.....	1,0	Coal and Sand (Rotary).....	1,5
Apron, Assembly, Belt, Chain, Flight, Oven.....	1,0	LINE SHAFTS		Bleacher.....	1,0	Vibrating.....	2,5	WOODWORKING MACHINES ..	1,0
Reciprocating.....	2,5	Driving Processing Machinery.....	1,0	Calender.....	2,0				
Screw.....	1,0	Light.....	1,0	Chipper.....	3,0				
CRANES AND HOISTS		LUMBER INDUSTRY		Couch, Cylinder, Dryer.....	1,5				
Main Hoist —		Band Resaw, Circular Resaw.....	1,5	Felt Stretcher.....	1,0				
Medium Duty.....	1,5	Edger, Head Rig, Hog, Log Haul	2,0	Fourdrinier.....	1,5				
Main Hoist —		Planer.....	1,5	Jordan.....	2,0				
Heavy Duty.....	2,0	Rolls Non-Reversing.....	1,5	Press.....	2,0				
Skip Hoist, Travel Motion, Trolley Motion, Slope.....	1,5	Rolls Reversing.....	2,0	Pulp Grinder.....	2,0				
CRUSHERS		Sawdust Conveyor.....	1,0	Stock Chest.....	1,5				
Cane.....	2,0	Slab Conveyor, Sorting Table.....	1,5	Stock Pump.....	2,0				
Gyratory.....	2,5	MACHINE TOOLS		Reciprocating.....	2,0				
DREDGES		Auxiliary.....	1,0	Rotary.....	1,5				
Cable Reel, Conveyor.....	1,5	Main Drive, Notching Press, Planer (Reversing), Plate Planer, Punch Press.....	1,5	Suction Roll.....	2,0				
Cutter Head Drive, Jog Drive.....	2,5	Traverse.....	1,0	Winder.....	1,5				
				PARAFFIN FILTER PRESS	1,5				
				PRINTING PRESS	1,5				
				PROPELLER (Marine)	1,5				
				PULVERIZERS					
				Hammemill — Light Duty ..	1,5				
				Hammemill — Heavy Duty..	2,0				

The service factors listed are intended only as a general guide for smooth power sources such as electric motors and steam turbines. Add 0,5 to factor for somewhat rougher power sources such as internal combustion engines of four or more cylinders , steam engines and water turbines. Where substantial shock occurs or starting or stopping is frequent as on some "inching" drives and on some reversing drives or where the power source is an internal combustion engine with less than four cylinders — consult factory. Where torsional vibrations occur as in, for example, internal combustion engines or reciprocating compressors or pump applications, check the coupling for possible development of damaging large amplitude vibrations.

** Add 0,5 to factor if without flywheel.

Chart 2 Size Selection

