



GreatOrientalTrading  
www.gotrading.co.th



@gotrading



GreatOrientalTrading



097-3619703



GSD Industrial Co.,Ltd.

# GHS

## 单级单吸卧式离心泵

GHS single-stage single-suction horizontal centrifugal pump



# GHS单级单吸卧式离心泵

## GHS single-stage single-suction horizontal centrifugal pump



### 特点 Features

- GHS系列单级单吸离心泵依据EN733 (DIN24255) 标准设计。
  - GHS结构简单, 性能可靠, 体积小, 重量轻, 抗汽蚀性能好, 电耗低, 使用维修方便。
  - GHS为后开式, 拆开泵盖和叶轮时不需拆卸吸水和排出管路, 维修方便。
  - 零件通用性广, 全系列46种型号, 只采用六种轴, 零件通用, 互换性好。
  - 规格相同的泵因改变叶轮外径(切割叶轮)而有不同的性能(在泵型号上加上ABC表示)。
  - 从驱动端看, 泵为顺时针方向旋转。
- The GHS series single-stage single-suction horizontal centrifugal pump is designed in accordance with EN733(DIN24255).
  - The GHS has simple structure, reliable performance, small volume, light weight, good pitting resistance, low power consumption and easy operation and maintenance.
  - The GHS is of the rear-open type. The suction and discharge pipes needn't be taken down for pump cover and impeller disassembly.
  - The GHS parts are universally replaceable. The whole series have 46 models that only adopt six types of shaft. All parts may be universally exchanged.
  - The pumps of the same specifications may have different performances (indicated with ABC on pump models) if changed in impeller outer diameters (cutting impeller).
  - The pump rotates in the clockwise direction if viewed from the driven end.

### 用途 Application

GHS系列单级单吸卧式离心泵适用于输送清水或物理化学性质类似于水的液体, 工厂、矿山、城市给排水、空调、消防和农田排灌等。

The GHS series single-stage single-suction horizontal centrifugal pump is used to convey clean water and the liquid with chemical and physical properties similar to water. It may be applied in water supply and drainage for factories, mines and cities, air conditioning, fire fighting and agricultural irrigation .



## 主要零件介绍

- 泵壳：底脚支承结构,螺旋形涡壳。涡室、底脚、进水法兰和出口法兰铸成一个整体,法兰可按工制或美制钻孔。
- 叶轮：闭式叶轮,采用优秀水力模型设计,保证泵的性能与效率,并进行动平衡试验。
- 悬架(轴承部件)：悬架内装有轴承,全系列共有6种轴承规格,轴承用润滑油(部分规格)或润滑脂润滑。
- 轴封：使用机械密封及填料密封共用结构,可选用国产及进口优质机封。
- 电机：选用优质高效节能电机,噪音低,振动小,也可根据需要配用防爆或特殊要求电机,泵通过弹性联轴器由电机直接驱动。

## 工作条件

- 出口口径：DN32~300mm。
- 流量范围：4.5~1660 m<sup>3</sup>/h。
- 扬程范围：5.2~150m。
- 转速：1450 r/min和2900 r/min (50Hz电源) 1750 r/min和3500 r/min (60Hz电源,叶轮为60Hz时,叶轮直径有所减少)
- 输送介质温度：-10°C~85°C (超过温度范围,请与我司咨询)。
- 工作压力：一般为1.6MPa,如需提高(最高可承受2.5 MPa),请在订货时说明。

## 结构简图 Construction

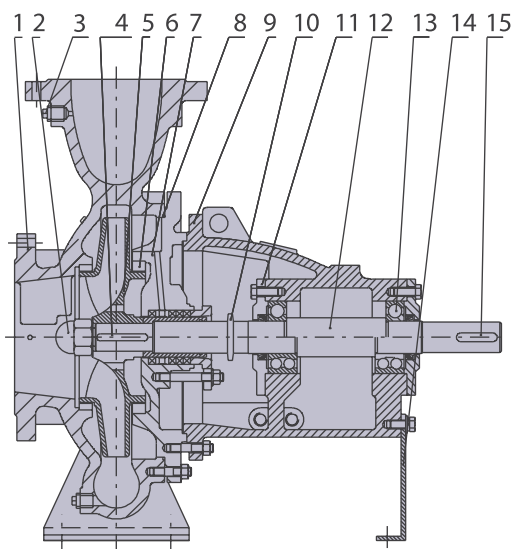

## The instruction of main parts

- Pump case: foot support structure and spiral volute chamber, with volute chamber, foot, influent flange and discharge flange cast into an integrity. The flanges may be drilled accordance with international stand ISO2084 DN16 or as requirement
- Impeller: closed impeller designed in the excellent hydraulic model to guarantee pump performance and efficiency. The dynamic balance test shall be conducted.
- Suspension fork (bearing part): the suspension fork is installed with bearing inside. There are totally 6 bearing specifications for the whole series. The bearings shall be lubricated by lubricating oil (for some specifications) or grease.
- Shaft seal: common structure for both mechanical seal and packing seal. Domestic and imported high-quality mechanical seal may also be adopted.
- Electrical motor: high-quality, high-efficiency and energy saving motor with low noise and small vibration. Anti-force motor or other motors with special requirements may be adopted if necessary. The pump is driven directly by electrical motor with elastic coupling.

## Working condition

- Outlet : DN32 ~ 300 mm.
- Capacity: 4.5 ~ 1660 m<sup>3</sup>/h.
- Head: 5.2 ~ 150m.
- Rotation Speed: 1450 r/min and 2900 r/min (50Hz power supply) 1750 r/min and 3500 r/min (60Hz power supply). The impeller shall have reduced diameter if with 60Hz).
- Conveyance medium temperature: - 10°C ~ 85°C (consult us if the temperature is beyond the above scope).
- Working pressure: 1.6Mpa is standard, available for up to max working pressure 2.5Mpa (please specify in your order)

NO.	名称 NAME	
01	泵体	Pump body
02	盖形螺母	Cap nut
03	丝堵	Pipe plug
04	叶轮平键	Impeller flat key
05	叶轮	Impeller
06	密封环	Wear ring
07	泵盖	Pump cover
08	泵体O型圈	Pump body O-ring
09	悬架	Suspension
010	挡水圈	Water deflector
011	轴盖	Shaft cap
012	轴	Shaft
013	轴承	Bearing
014	悬架支架	Suspension support
015	泵联平键	Pump connection flat key



## 结构特性 Construction features

### 轴承结构及润滑方式 Bearing structure and lubrication mode

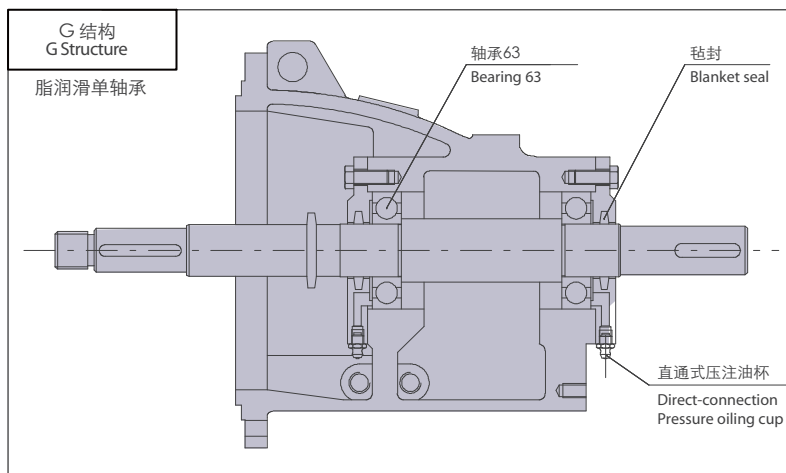

G结构：脂润滑结构，适用所有泵型(标准配置)

G structure: grease lubrication structure, suitable for all pump models (Standard)

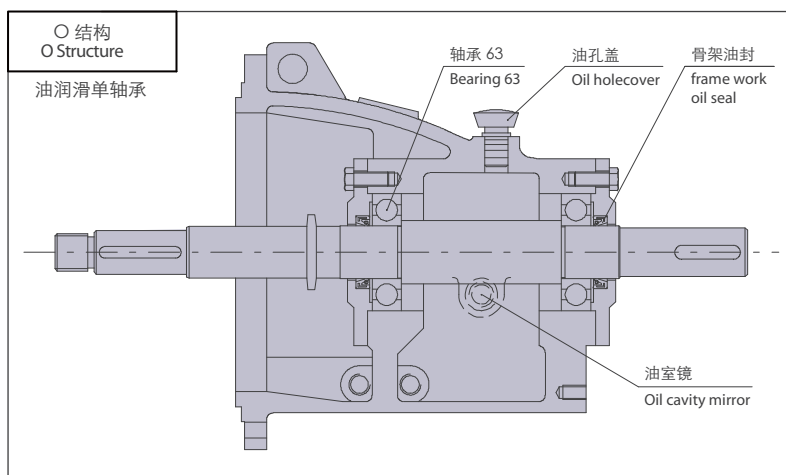

O结构：油润滑结构，适用所有泵型(可选配置)

O structure: oil lubrication structure, suitable for all pump models (Optional)

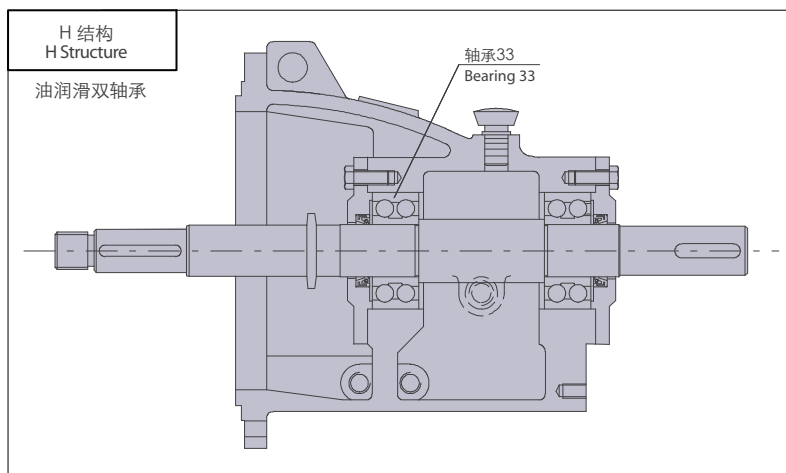

H结构：单指GHS 40/320；GHS50/320；GHS65/320；GHS80/160；GHS80/320以上五型泵，可配置高转速泵用。

H structure: only suitable for pump models of GHS40/320, GHS50/320, GHS65/320, GHS80/160 and GHS80/320



## 轴封结构 Shaft seal structure

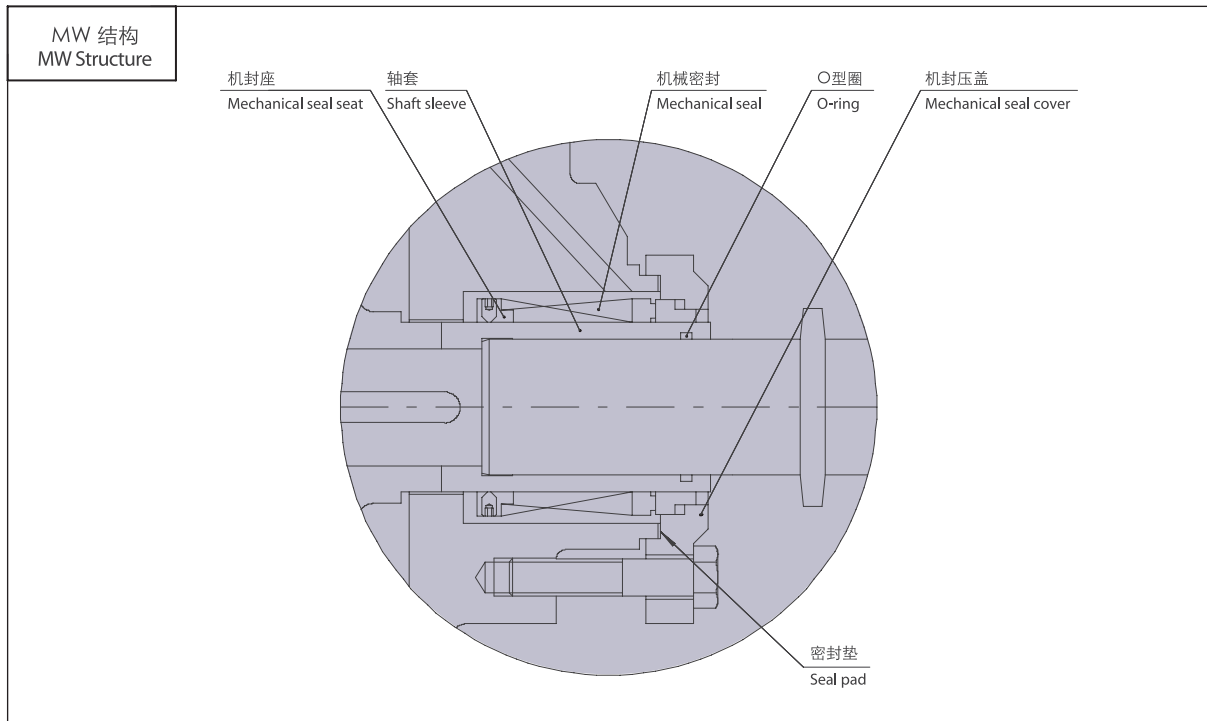

MW结构:外装式非平衡式机械密封结构。  
MW structure: outside-fitted non-equilibrium mechanical seal structure.

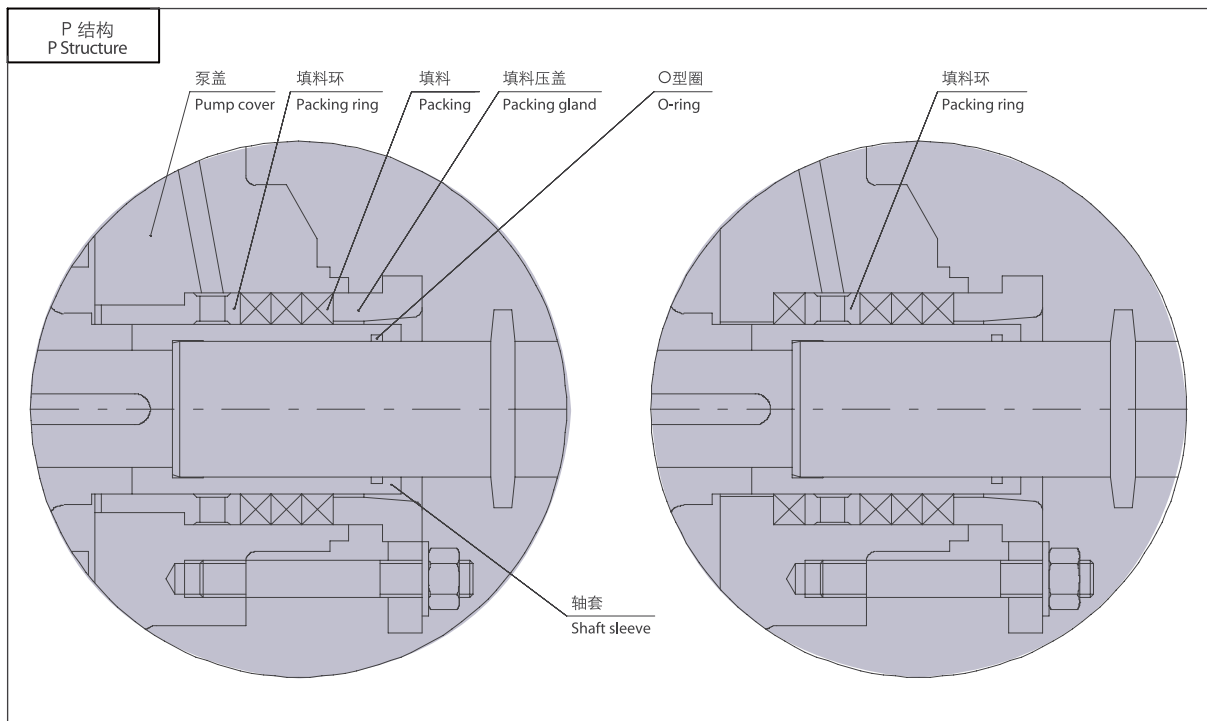

P结构:外装式填料密封结构,主要用于可容许少量泄漏之场所  
P structure: outside-fitted packing seal structure, mainly used in the place with small leakage.



## 密封环结构 Wear ring structure

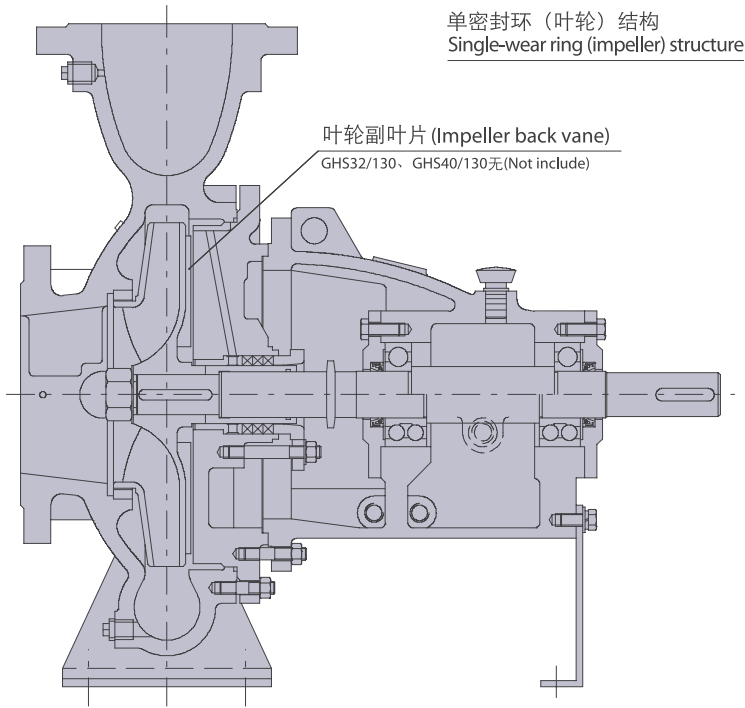

泵规格 Pump specifications
GHS 32/130
GHS 40/130
GHS 50/130
GHS 65/130
GHS 32/160
GHS 40/160
GHS 50/160
GHS 65/160
GHS 80/160
GHS 32/200
GHS 40/200
GHS 50/200
GHS 65/200
GHS 80/200
GHS 100/200
GHS 125/200
GHS 32/260
GHS 40/260
GHS 50/260
GHS 65/260
GHS 80/260
GHS100/260
GHS125/260

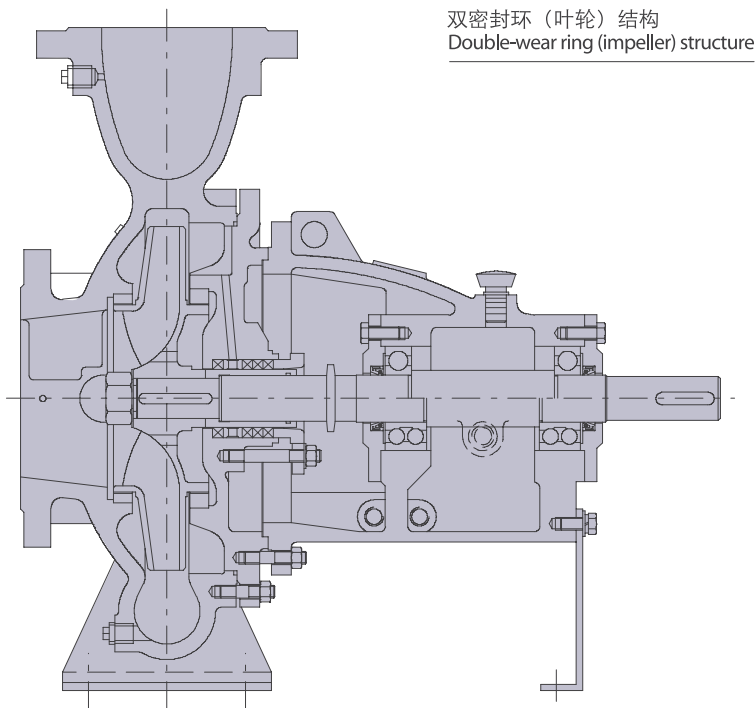

泵规格 Pump specifications
GHS150/200
GHS150/260
GHS200/260
GHS 40/320
GHS 50/320
GHS 65/320
GHS 80/320
GHS100/320
GHS125/320
GHS150/320
GHS200/320
GHS250/320
GHS 80/400
GHS100/400
GHS125/400
GHS150/400
GHS200/400
GHS250/400
GHS300/400
GHS125/500
GHS150/500
GHS200/500
GHS250/500

单密封环结构: 叶轮进水面设有密封环, 背面设有副叶片, 依靠副叶片平衡轴向力

双密封环结构: 叶轮进水面设有密封环, 背面设有密封环, 平衡孔, 依靠平衡孔平衡轴向力

Single-wear ring structure: the influent side of impeller is set with wear ring, and the back is set with back vane for balancing axial thrust

Double-wear ring structure: the influent side of impeller is set with wear ring, and the back is set with wear ring and balance hole for balancing axial thrust



## 泵主要零件材料表 The material of main parts

零件名称 Part name		材料名称 Material	材质 Material			
			中国 GB	台湾 CNS	日本 JIS	德国 DIN
泵体 Pump casing	标准配置 Standard	灰口铸铁 Cast iron	HT250	FC250	FC25	GG25
	可选配置 Optional	球墨铸铁 Nodular cast iron	QT400	—	FCD400	GGG40
			QT450	—	FCD450	GGG45
		铸钢 Cast-steel	ZG35	SC480	SC480	DS-52
		不锈钢 Stainless steel	1Cr18Ni9Ti	321	SUS321	X12CrNiTi18-9
			0Cr18Ni9	304	SUS304	X5GrNi18-10
铸铜(铝青铜) Cast copper	ZCuAl10Fe3(ZQA19-4)	—	A1BC1	G-CuAl10Fe		
轴 Shaft	标准配置 Standard	不锈钢 Stainless steel	2Cr13	420J1	SUS420J1	X20Cr13
	可选配置 Optional	碳钢 Carbon steel	45	S45C	S45C	C45E
		不锈钢 Stainless steel	1Cr17Ni2	431	SUS431	X20CrNi17-2
			1Cr18Ni9Ti	321	SUS321	X12CrNiTi18-9
叶轮 密封环 Impeller wearing	标准配置 Standard	灰铸铁 Cast iron	HT250	FC250	FC25	GG25
	可选配置 Optional	球墨铸铁 Ductile cast iron	QT400	FCD400	FCD400	GGG40
			QT450	FCD400	FCD450	GGG45
		铸钢 Cast steel	ZG35	SC480	SC480	DS-52
		不锈钢 Stainless steel	1Cr18Ni9Ti	321	SUS321	X12CrNiTi18-9
			0Cr18Ni9	304	SUS304	X5GrNi18-10
		铸铜 (铝青铜/锡青铜) Cast copper	ZCuAl10Fe3(ZQA19-4)	—	A1BC1	G-CuAl10Fe
	ZCuSn5Pb5Zn5(ZQSn5-5-5)		—	BC6	G-CuSn5Zn5Pb(2.1096.01)	
轴套 Shaft sleeve	标准配置 Standard	不锈钢 Stainless steel	1Cr18Ni9Ti	321	SUS321	X12CrNiTi18-9
	可选配置 Optional	不锈钢 Stainless steel	0Cr18Ni9	304	SUS304	X5GrNi18-10
			0Cr18Ni12Mo12Ti	—	—	X6CrNiMoTi17-12-2
轴封 Shaft seal	标准配置 Standard	填料密封 Gland packing	—			
	可选配置 Optional	机械密封 Mechanical seal	Carbon-Ceramic-NBR			
			Silicon-Silicon-NBR			



## 型号说明 Type description

GHS - 32 - 130 A

- 叶轮外径第一次切割  
The first cutting of impeller outer diameter
- 叶轮名义直径(mm)  
Impeller nominal diameter (mm)
- 泵出口法兰直径(mm)  
Pump outlet flange diameter (mm)
- GHS系列单级单吸卧式离心泵  
GHS series single-stage single-suction horizontal centrifugal pump

## 性能曲线 Performance curves

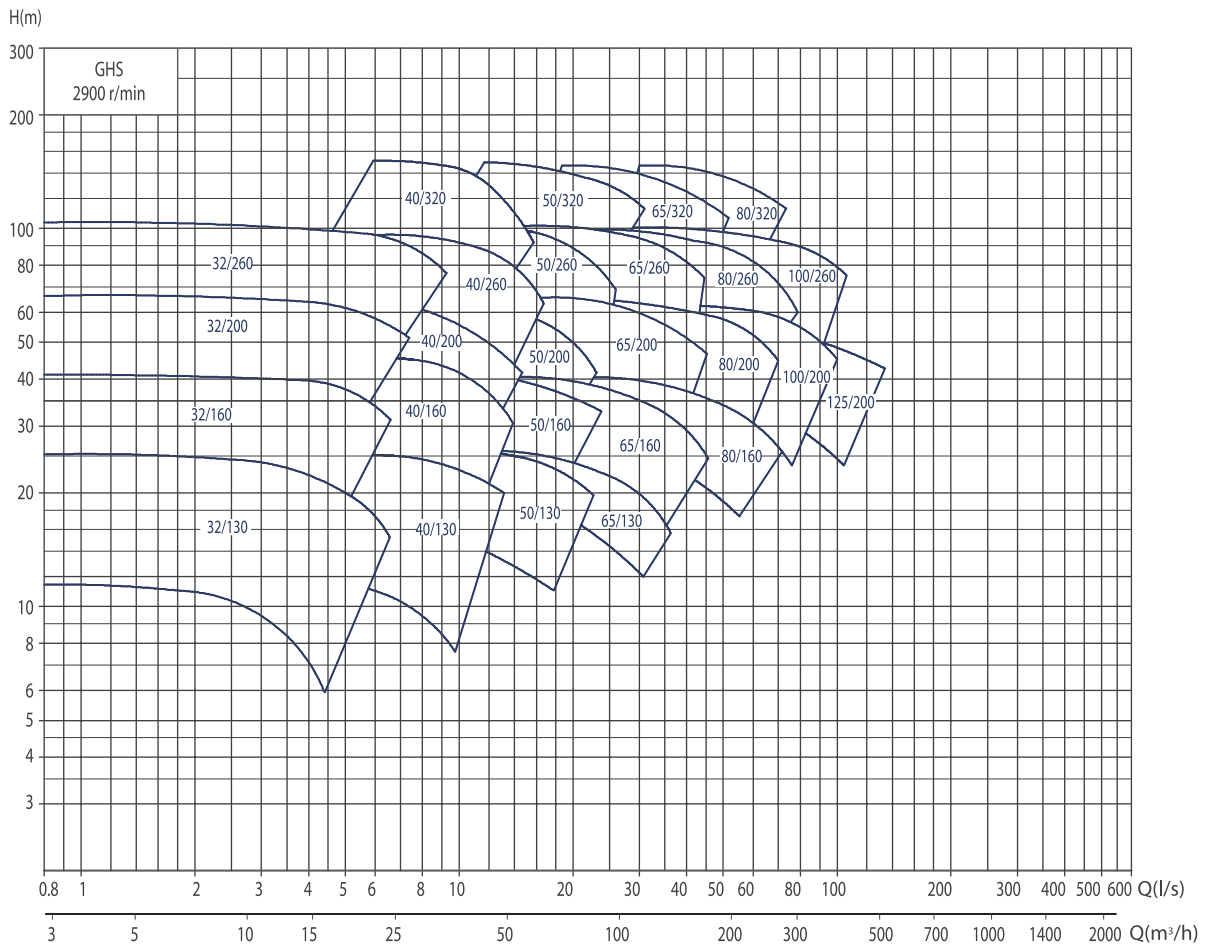



## 性能曲线 Performance curves

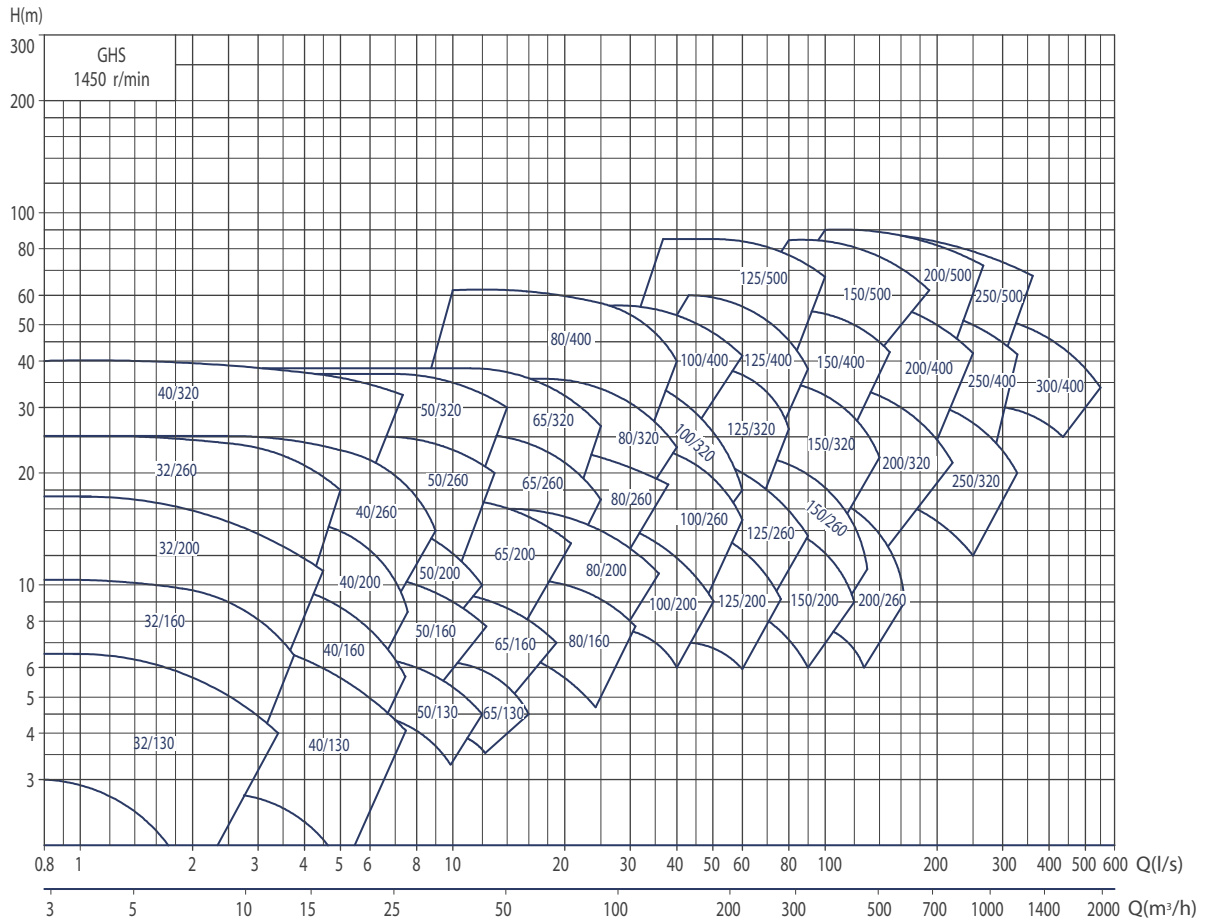

## 性能参数 Performance parameters

(2P)

泵型号 Pump model	流量 capacity		扬程 head h (m)	转速 speed n (r/min)	轴功率 shaft power (kW)	效率 eff. η (%)	必需汽 蚀余量 npshr (m)	泵口径 pump (mm)		泵重量 weight (kg)
	m <sup>3</sup> /h	l/s						吸入 suction	排出 discharge	
GHS32/130	9	2.5	24.9	2900	1.23	44	1.8	50	32	27.5
	15	4.2	23		1.47	55	2.0			
	18	5.0	21		1.58	56	2.5			
GHS32/130A	8.5	2.4	21.2	2900	1.04	43.5	1.8	50	32	27.5
	14	3.9	19		1.23	54	1.95			
	17	4.7	17.3		1.32	53	2.3			
GHS32/130B	7.8	2.2	17.3	2900	0.89	42	1.8	50	32	27.5
	13	3.6	15.3		1.02	51	1.88			
	15.5	4.3	13.8		1.07	52	2.08			
GHS32/160	10.8	3.0	40	2900	2.50	47	1.2	50	32	35
	18	5.0	38.5		3.23	58.5	2			
	21.6	6.0	36		3.59	59	2.6			
GHS32/160A	10.5	2.9	35.7	2900	2.22	46	1.9	50	32	35
	17	4.7	33		2.78	55	1.95			
	21	5.8	30		3.06	56	2.4			
GHS32/160B	9.8	2.7	32.4	2900	1.97	44	1.9	50	32	35
	16	4.4	29.5		2.43	53	1.95			
	19.5	5.4	27		2.66	54	2.2			
GHS32/200	10.8	3.0	66	2900	4.51	43	1.3	50	32	41
	18	5.0	61.5		5.74	52.5	1.9			
	21.6	6.0	57		6.27	53.5	2.3			
GHS32/200A	10.2	2.8	58.2	2900	4.04	40	1.8	50	32	41
	17	4.7	55.8		4.87	53	1.95			
	20.4	5.7	52.2		5.47	53	2.2			
GHS32/200B	9.9	2.8	51.5	2900	3.65	38	1.8	50	32	41
	16.5	4.6	48		4.40	49	1.9			
	19.8	5.5	45		4.97	48.8	2.15			
GHS32/260	13.2	3.7	102	2900	11.21	32.7	1.8	50	32	59
	22	6.1	96		14.10	40.8	2.7			
	26.4	7.3	89		15.61	41	3.3			
GHS32/260A	12.6	3.5	92.5	2900	10.11	31.4	2.1	50	32	59
	21	5.8	88		12.58	40	2.2			
	25.2	7.0	83		13.89	41	2.5			
GHS32/260B	12.3	3.4	84.5	2900	9.43	30	2.15	50	32	59
	20.5	5.7	81		11.75	38.5	2.16			
	24.6	6.8	77		12.90	40	2.38			
GHS40/130	18	5.0	26	2900	2.09	61	1.8	65	40	30
	30	8.3	24.5		2.65	75.5	2.0			
	36	10.0	23		2.91	77.5	2.4			
GHS40/130A	16.8	4.7	22.5	2900	1.74	59	1.8	65	40	30
	28	7.8	21		2.29	70	2			
	33.6	9.3	20		2.54	72	2.25			
GHS40/130B	15.5	4.3	18.5	2900	1.47	53	1.8	65	40	30
	26	7.2	17.5		1.91	65	1.9			
	31	8.6	16.5		2.14	65	2.15			
GHS40/160	18	5.0	41	2900	3.72	54	2.1	65	40	36
	30	8.3	38.5		4.91	64	2.5			
	36	10.0	35.5		5.40	64.5	3.6			
GHS40/160A	17	4.7	36	2900	3.21	52	2.1	65	40	36
	28.5	7.9	33.5		4.00	65	2.5			
	34	9.4	31		4.63	62	3.25			
GHS40/160B	16	4.4	31.5	2900	2.86	48	2.05	65	40	36
	26.5	7.4	29		3.52	62	2.4			
	32	8.9	25.5		3.77	59	2.9			
GHS40/200	18	5.0	64	2900	6.54	48	1.85	65	40	44
	30	8.3	61		8.38	59.5	2.0			
	36	10.0	58.6		9.27	62	2.7			
GHS40/200A	17	4.7	58.5	2900	5.58	48.5	1.8	65	40	44
	29	8.1	56		7.25	61	1.95			
	34.5	9.6	53.5		7.98	63	2.45			
GHS40/200B	16.5	4.6	52.5	2900	5.13	46	1.8	65	40	44
	27.5	7.6	49		6.22	59	1.9			
	33	9.2	47		6.92	61	2.2			
GHS40/260	21.6	6.0	98.5	2900	12.88	45	1.8	65	40	61
	36	10.0	95.5		16.72	56	2.0			
	43.2	12.0	91		18.15	59	2.5			
GHS40/260A	19.5	5.4	89	2900	11.25	42	1.8	65	40	61
	32	8.9	87		14.31	53	1.95			
	38.5	10.7	84		16.01	55	2.35			



## 性能参数 Performance parameters

(2P)

泵型号 Pump model	流量 capacity		扬程 head h (m)	转速 speed n (r/min)	轴功率 shaft power (kW)	效率 eff. η (%)	必需汽 蚀余量 npshr (m)	泵口径 pump (mm)		泵重量 weight (kg)
	m <sup>3</sup> /h	l/s						吸入 suction	排出 discharge	
GHS40/260B	18.5	5.1	80	2900	10.08	40	1.8	65	40	61
	30.5	8.5	78		12.22	53	1.9			
	37	10.3	76		14.18	54	2.2			
GHS40/320H	21.6	6.0	150	2900	25.95	34	2	65	40	95.8
	36	10.0	139		30.97	44	2.8			
	43.2	12.0	127		33.20	45	3.8			
GHS40/320HA	19.44	5.4	124	2900	19.31	34	1.9	65	40	95.8
	32.4	9.0	115		23.60	43	2.9			
	38.88	10.8	107		25.75	44	3.8			
GHS40/320HB	17.28	4.8	109	2900	16.03	32	1.7	65	40	95.8
	28.8	8.0	102		19.51	41	2.6			
	34.56	9.6	95		21.29	42	3.2			
GHS50/130	36	10.0	26	2900	3.78	67.5	2.5	65	50	34
	60	16.7	23.5		5.05	76	3.2			
	72	20.0	21.5		5.66	74.5	4			
GHS50/130A	33.5	9.3	21.5	2900	3.04	64.5	2.5	65	50	34
	56	15.6	18.5		4.00	70.5	3.1			
	67.5	18.8	15.5		4.35	65.5	3.6			
GHS50/130B	31	8.6	18.5	2900	2.56	61	2.5	65	50	34
	52	14.4	16.5		3.34	70	2.9			
	62	17.2	15		3.67	69	3.3			
GHS50/160	40	11.1	42.5	2900	6.76	68.5	2.5	65	50	38
	65	18.1	39		9.08	76	3.5			
	78	21.7	35.5		10.26	73.5	4.2			
GHS50/160A	38	10.6	38	2900	5.62	70	2.5	65	50	38
	61.5	17.1	34.5		7.60	76	3.3			
	74	20.6	30		8.17	74	3.9			
GHS50/160B	35.5	9.9	34	2900	4.63	71	2.35	65	50	38
	58	16.1	30.5		6.42	75	3.1			
	69.5	19.3	28		7.26	73	3.7			
GHS50/200	36	10.0	61	2900	9.34	64	1.9	65	50	46
	60	16.7	55		12.84	70	3.2			
	72	20.0	51		14.39	69.5	4.1			
GHS50/200A	34.5	9.6	57	2900	8.93	60	2.5	65	50	46
	57.5	16.0	53		11.53	72	3.1			
	69	19.2	50.5		13	73	3.75			
GHS50/200B	33	9.2	49.5	2900	7.18	62	2.5	65	50	46
	54.5	15.1	43		9.39	68	3.0			
	65.5	18.2	38		10.27	66	3.5			
GHS50/260G	40	11.1	103	2900	20.78	54	2.5	65	50	63
	65	18.1	97.5		27.18	63.5	3.5			
	78	21.7	91		30.68	63	4.2			
GHS50/260GA	38.5	10.7	91.5	2900	19.19	50	2.4	65	50	63
	63	17.5	85.5		24.45	60	3.3			
	75.5	21.0	80		26.75	61.5	3.9			
GHS50/260GB	37	10.3	84	2900	16.93	50	2.3	65	50	63
	60.5	16.8	77		21.14	60	3.2			
	72.5	20.1	71		24.17	58	3.9			
GHS50/320H	54	15.0	146	2900	40.51	53	3.5	65	50	101
	90	25.0	137		55.05	61	7.0			
	108	30.0	130		61.67	62	8.0			
GHS50/320HA	48.6	13.5	130	2900	34.41	50	3.3	65	50	101
	81	22.5	124		45.59	60	6.5			
	97.2	27.0	117		50.77	61	7.5			
GHS50/320HB	46.8	13.0	105	2900	25.74	52	2.5	65	50	101
	78.12	21.7	98		35.04	59.5	5.0			
	93.6	26.0	91		39.32	59	6.5			
GHS65/130	60	16.7	25.5	2900	6.27	69	3.0	80	65	39
	100	27.8	21		8.17	70	3.5			
	120	33.3	16		8.86	59	4.5			
GHS65/130A	56	15.6	21.8	2900	5.11	65	3	80	65	39
	93.5	26.0	17.5		6.37	70	3.5			
	112.5	31.3	13		6.99	57	4.1			
GHS65/130B	52	14.4	18	2900	4.08	62.5	3	80	65	39
	86.5	24.0	13.7		4.89	66	3.3			
	104	28.9	10.6		5.27	57	3.75			
GHS65/160	64.8	18.0	39	2900	9.97	69	3.6	80	65	43
	108	30.0	33.5		12.71	77.5	4.2			
	129.6	36.0	29		14.22	72	5.2			



## 性能参数 Performance parameters

(2P)

泵型号 Pump model	流量 capacity		扬程 head h (m)	转速 speed n (r/min)	轴功率 shaft power (kW)	效率 eff. η (%)	必需汽 蚀余量 npshr (m)	泵口径 pump (mm)		泵重量 weight (kg)
	m <sup>3</sup> /h	l/s						吸入 suction	排出 discharge	
GHS65/160A	57	15.8	34	2900	8.38	63	3.6	80	65	43
	95	26.4	30.5		10.66	74	4.1			
	114	31.7	27		11.81	71	4.8			
GHS65/160B	53.5	14.9	30	2900	7.28	60	3.6	80	65	43
	89	24.7	25.5		8.83	70	3.95			
	107	29.7	22.5		9.50	69	4.5			
GHS65/200G	66	18.3	64	2900	17.7	65	3.0	80	65	70
	110	30.6	59		23.72	74.5	3.9			
	132	36.7	54.5		26.66	73.5	5.3			
GHS65/200GA	63	17.5	60	2900	16.08	64	3.0	80	65	70
	105.5	29.3	55.5		21.55	74	3.9			
	126.5	35.1	52		24.37	73.5	5.3			
GHS65/200GB	60	16.7	50	2900	13.18	62	3.0	80	65	70
	100	27.8	45.5		16.41	75.5	3.6			
	120	33.3	42		18.30	75	4.4			
GHS65/260	72	20.0	98	2900	29.79	64.5	3.3	80	65	81
	120	33.3	90		42.29	73	4.5			
	144	40.0	83		44.59	73	5.4			
GHS65/260A	69.5	19.3	92	2900	26.79	65	3.25	80	65	81
	116	32.2	86		38.81	70	4.4			
	139	38.6	79		41.53	72	4.95			
GHS65/260B	67	18.6	82.5	2900	23.89	63	3.2	80	65	81
	111.5	31.0	76		32.50	71	4.25			
	133.5	37.1	71		36.88	70	4.95			
GHS65/320H	81	22.5	147	2900	60.05	54	3.8	80	65	110
	135	37.5	131		76.45	63	4.4			
	162	45.0	115		84.56	60	5.5			
GHS65/320HA	81	22.5	120	2900	48.13	55	3.7	80	65	110
	135	37.5	108		64.04	62	4.3			
	162	45.0	97		73.78	58	5.2			
GHS65/320HB	81	22.5	107	2900	40.00	59	3.5	80	65	110
	135	37.5	94		56.65	61	4.3			
	162	45.0	83		67.81	54	4.8			
GHS80/160H	100	27.8	39.5	2900	15.15	71	3.3	100	80	54
	162	45.0	35		19.80	78	4.0			
	195	54.2	31		21.95	75	5.0			
GHS80/160HA	95	26.4	33	2900	13.13	65	3.3	100	80	54
	153.5	42.6	28		16.26	72	3.85			
	185	51.4	24		17.78	68	4.6			
GHS80/160HB	89	24.7	29.5	2900	11.17	64	3.25	100	80	54
	144.5	40.1	25		13.29	74	3.7			
	174	48.3	21		14.22	70	4.3			
GHS80/200	115	31.9	60	2900	26.84	70	4.0	100	80	70
	190	52.8	55		36.49	78	5.1			
	225	62.5	50		41.12	74.5	6.2			
GHS80/200A	110	30.6	57	2900	25.11	68	4.0	100	80	70
	182	50.6	53.5		34.44	77	4.9			
	215.5	59.9	44.5		37.31	70	5.85			
GHS80/200B	105	29.2	49.5	2900	20.82	68	4.0	100	80	70
	173	48.1	45		27.90	76	4.7			
	205	56.9	40		31.90	70	5.5			
GHS80/260	115	31.9	97	2900	46.74	65	4.0	100	80	91
	190	52.8	88		60.71	75	5.4			
	225	62.5	81		67.53	73.5	6.5			
GHS80/260A	111	30.8	91.5	2900	43.90	63	3.95	100	80	91
	183.5	51.0	81.5		54.30	75	5.2			
	217.5	60.4	73		59.23	73	6.25			
GHS80/260B	106.5	29.6	79	2900	37.56	61	3.9	100	80	91
	176.5	49.0	68.5		45.10	73	5			
	209	58.1	60		48.10	71	6			
GHS80/320H	126	35.0	146	2900	78.28	64	5.6	100	80	120
	210	58.3	134		103.56	74	6.3			
	252	70.0	121		113.75	73	7			
GHS80/320HA	117	32.5	125	2900	64.24	62	6.1	100	80	120
	195	54.2	114		82.93	73	6.3			
	234	65.0	103		91.16	72	6.9			
GHS80/320HB	108	30.0	104	2900	47.79	64	5	100	80	120
	180	50.0	95		63.79	73	5.8			
	216	60.0	85		71.43	70	6.3			



## 性能参数 Performance parameters

(2P/4P)

泵型号 Pump model	流量 capacity		扬程 head h (m)	转速 speed n (r/min)	轴功率 shaft power (kW)	效率 eff. η (%)	必需汽 蚀余量 npshr (m)	泵口径 pump (mm)		泵重量 weight (kg)
	m <sup>3</sup> /h	l/s						吸入 suction	排出 discharge	
GHS100/200	180	50.0	61	2900	41.53	72	4.0	125	100	85
	295	81.9	51.5		52.37	79	5.3			
	340	94.4	42		52.55	74	6.3			
GHS100/200A	172.5	47.9	51	2900	34.72	69	3.95	125	100	85
	273	75.8	42		42.20	74	4.9			
	325.5	90.4	36		46.25	69	5.95			
GHS100/200B	164	45.6	46	2900	30.21	68	3.9	125	100	85
	260	72.2	35		35.40	70	4.8			
	310	86.1	31		39.06	67	5.6			
GHS100/260	190	52.8	97	2900	70.69	71	3.8	125	100	106
	295	81.9	86		90.91	76	5.2			
	350	97.2	80		103.04	74	6.5			
GHS100/260A	183.5	51.0	85.5	2900	61.92	69	3.75	125	100	106
	285	79.2	75		78.66	74	5			
	338	93.9	66		85.57	71	6.2			
GHS100/260B	177	49.2	76	2900	54.68	67	3.7	125	100	106
	274	76.1	66		68.4	72	4.8			
	325	90.3	58		75.49	68	5.9			
GHS125/200	237.6	66.0	57.5	2900	57.68	64.5	7	150	125	106
	360	100.0	50.5		66.46	74.5	7.2			
	475.2	132.0	40		76.12	68	7.8			
GHS32/130	4.5	1.3	6.2	1450	0.22	35	1.8	50	32	27.5
	7.5	2.1	5.6		0.25	46	2.0			
	9	2.5	5.2		0.26	49	2.3			
GHS32/160	6	1.7	9.7	1450	0.38	42	0.7	50	32	35
	9	2.5	9		0.46	48	1.0			
	11	3.1	8		0.48	49.5	1.4			
GHS32/200	6	1.7	16.3	1450	0.67	40	1.8	50	32	41
	9	2.5	15.4		0.79	48	2.0			
	11	3.1	14.5		0.85	51	2.3			
GHS32/260	7.2	2.0	25	1450	1.63	30	1.8	50	32	59
	12	3.3	23.5		1.94	39.5	2.0			
	14.4	4.0	22		2.05	42	2.3			
GHS40/130	10.8	3.0	6.55	1450	0.34	57	1.8	65	40	30
	18	5.0	5.8		0.42	67	2.0			
	21.6	6.0	5.4		0.47	67	2.4			
GHS40/160	10.8	3.0	10.2	1450	0.55	55	1.8	65	40	36
	18	5.0	8.8		0.70	62	2.0			
	21.6	6.0	7.8		0.76	60	2.4			
GHS40/200	10.8	3.0	16.2	1450	0.95	50	1.8	65	40	44
	18	5.0	14		1.23	56	2.0			
	21.6	6.0	12.4		1.33	55	2.4			
GHS40/260	12.6	3.5	24.4	1450	1.99	42	1.8	65	40	61
	21	5.8	22		2.42	52	2.0			
	25.2	7.0	20		2.61	52.5	2.4			
GHS40/320	9	2.5	38	1450	3.10	30	3.1	65	40	95.8
	14.4	4.0	37.5		3.50	42	2.1			
	18	5.0	37		4.03	45	3.8			
GHS40/320A	10.5	2.9	34.5	1450	3.23	30.5	3.3	65	40	95.8
	17	4.7	32		3.85	38.5	2			
	20.5	5.7	29		4.32	37.5	2.9			
GHS40/320B	10	2.8	31	1450	2.91	29	3.6	65	40	95.8
	16.5	4.6	29		3.52	37	2			
	20	5.6	26		3.93	36	2.7			
GHS50/130	18	5.0	6.6	1450	0.54	60	2.2	65	50	34
	30	8.3	6.3		0.68	75.5	2.4			
	36	10.0	5.7		0.76	74	2.8			
GHS50/160	20	5.6	10.4	1450	0.89	64	2.3	65	50	38
	32	8.9	9.8		1.15	74.3	2.4			
	38	10.6	9.4		1.31	74.5	3.0			
GHS50/200	18	5.0	16	1450	1.35	58	2.2	65	50	46
	30	8.3	14		1.79	64	2.3			
	36	10.0	13.5		2.04	65	2.9			
GHS50/260	20	5.6	25	1450	2.59	52.5	2.3	65	50	63
	32	8.9	24		3.24	64.5	2.4			
	38	10.6	23		3.58	66.5	3.0			
GHS50/320	32.4	9.0	37	1450	5.78	56.5	2.0	65	50	101
	54	15.0	30.5		7.80	57.5	2.5			
	64.8	18.0	23.5		8.73	47.5	3.2			



## 性能参数 Performance parameters

(4P)

泵型号 Pump model	流量 capacity		扬程 head h (m)	转速 speed n (r/min)	轴功率 shaft power (kW)	效率 eff. η (%)	必需汽 蚀余量 npshr (m)	泵口径 pump (mm)		泵重量 weight (kg)
	m <sup>3</sup> /h	l/s						吸入 suction	排出 discharge	
GHS50/320A	23	6.4	33.5	1450	4.20	50	2.0	65	50	101
	38.5	10.7	31.3		5.29	62	2.4			
	46	12.8	30		5.97	63	3.0			
GHS50/320B	22	6.1	29.8	1450	3.57	50	2.0	65	50	101
	36.5	10.1	28.5		4.64	61	2.3			
	44	12.2	27		5.22	62	2.8			
GHS65/130	21.6	6.0	6.7	1450	0.79	50	2.2	80	65	39
	36	10.0	6.4		0.95	66	2.4			
	43.2	12.0	6		1.02	69	2.8			
GHS65/160	32.4	9.0	10	1450	1.38	64	2.0	80	65	43
	54	15.0	9.2		1.73	78	2.2			
	64.8	18.0	8.4		1.82	81.5	2.5			
GHS65/200	35	9.7	16.4	1450	2.37	66	1.9	80	65	52
	55	15.3	15		2.94	76.5	2.0			
	66	18.3	13.8		3.20	77.5	2.3			
GHS65/260	43.2	12.0	25.3	1450	4.48	66.5	2.0	80	65	81
	72	20.0	21.5		5.74	73.5	2.3			
	86.4	24.0	18.7		6.47	68	3.0			
GHS65/320	43.2	12.0	37.4	1450	7.46	59	1.9	80	65	110
	72	20.0	33		9.66	67	2.0			
	86.4	24.0	29		10.50	65	2.5			
GHS65/320A	37	10.3	34.5	1450	6.32	55	1.9	80	65	110
	62	17.2	32		8.31	65	2.0			
	74.5	20.7	28		9.16	62	2.3			
GHS65/320B	34	9.4	30.5	1450	6.01	47	2.0	80	65	110
	56.5	15.7	28		7.30	59	2.0			
	68	18.9	25.8		8.10	59	2.1			
GHS80/160	50	13.9	10.6	1450	2.31	62.5	2.1	100	80	54
	80	22.2	10		2.87	76	2.5			
	96	26.7	9.3		3.16	77	3.2			
GHS80/200	63	17.5	15.7	1450	3.59	75	2.1	100	80	70
	105.12	29.2	14		4.89	82	2.5			
	126	35.0	12.8		5.63	78	3.2			
GHS80/260	63	17.5	24	1450	5.88	70	2.1	100	80	91
	105.12	29.2	21		7.91	76	2.5			
	126	35.0	18.5		8.82	72	3.2			
GHS80/320	60	16.7	36	1450	9.41	62.5	1.9	100	80	120
	100	27.8	33		12.66	71	2.0			
	120	33.3	30		14.11	69.5	2.6			
GHS80/320A	57.5	16.0	34	1450	9.18	58	1.9	100	80	120
	95.5	26.5	29.7		11.19	69	2.0			
	114.5	31.8	26		11.92	68	2.3			
GHS80/320B	54.5	15.1	30.4	1450	8.06	56	1.9	100	80	120
	91	25.3	27.3		10.10	67	2.0			
	109	30.0	25		11.24	66	2.2			
GHS80/400	60	16.7	59	1450	17.37	55.5	2.2	100	80	161
	100	27.8	55.5		23.08	65.5	2.5			
	120	33.3	52.5		25.80	66.5	3.4			
GHS80/400A	59	16.4	55	1450	16.07	55	2.2	100	80	161
	96.5	26.8	52.5		21.56	64	2.4			
	116	32.2	49		24.57	63	3.2			
GHS80/400B	56	15.6	51	1450	14.40	54	2.2	100	80	161
	93	25.8	49		18.80	66	2.4			
	111.5	31.0	47		20.99	68	3.0			
GHS100/200	90	25.0	15	1450	4.60	80	2.2	125	100	85
	142	39.4	12.7		5.99	82	2.5			
	170	47.2	10.5		6.52	74.5	3.4			
GHS100/260	99	27.5	24	1450	8.51	76	2.3	125	100	115
	165	45.8	21		11.58	81.5	2.6			
	198	55.0	19		13.66	75	3.5			
GHS100/320	81	22.5	39	1450	11.95	72	2.0	125	100	134
	135	37.5	33.7		15.49	80	2.0			
	162	45.0	30		17.30	76.5	2.3			
GHS100/320A	77.5	21.5	34	1450	10.25	70	2.0	125	100	134
	130	36.1	29.5		13.74	76	2.0			
	155	43.1	26.5		15.32	73	2.2			
GHS100/320B	73.5	20.4	30	1450	8.96	67	2.0	125	100	134
	123	34.2	27		11.90	76	2.0			
	147.5	41.0	23		13.01	71	2.1			



## 性能参数 Performance parameters

(4P)

泵型号 Pump model	流量 capacity		扬程 head h (m)	转速 speed n (r/min)	轴功率 shaft power (kW)	效率 eff. η (%)	必需汽 蚀余量 npshr (m)	泵口径 pump (mm)		泵重量 weight (kg)
	m <sup>3</sup> /h	l/s						吸入 suction	排出 discharge	
GHS100/400	90	25.0	58.8	1450	23.82	60.5	1.7	125	100	174
	150	41.7	51		30.86	67.5	2.0			
	180	50.0	44		33.44	64.5	2.7			
GHS100/400A	87	24.2	54	1450	22.85	56	1.7	125	100	174
	145	40.3	48.2		28.84	66	2.0			
	174	48.3	42		29.97	66.4	2.5			
GHS100/400B	84	23.3	49.5	1450	20.97	54	1.7	125	100	174
	139.5	38.8	45.2		26.83	64	1.9			
	167.5	46.5	41.2		29.36	64	2.4			
GHS125/200	115	31.9	15.2	1450	7.68	62	2.6	150	125	106
	190	52.8	13		8.74	77	3.5			
	230	63.9	11.5		9.42	76.5	3.0			
GHS125/260	144	40.0	24.2	1450	12.82	74	2.3	150	125	106
	240	66.7	21.2		17.11	81	2.5			
	288	80.0	17		18.52	72	3.2			
GHS125/260A	139	38.6	21.3	1450	11.86	68	2.3	150	125	106
	232	64.4	18.2		14.56	79	2.5			
	278.5	77.4	15.4		15.57	75	3.0			
GHS125/260B	134	37.2	19.7	1450	9.71	74	2.3	150	125	106
	223	61.9	16		12.79	76	2.4			
	267.5	74.3	13.4		14.36	68	2.8			
GHS125/320	120	33.3	35	1450	16.95	67.5	2.1	150	125	163
	200	55.6	32.5		22.41	79	2.0			
	240	66.7	30		25.14	78	2.7			
GHS125/320A	115	31.9	32.8	1450	15.11	68	2.15	150	125	163
	191	53.1	29.5		19.93	77	1.95			
	229	63.6	27.5		22.87	75	2.4			
GHS125/320B	109	30.3	28.9	1450	11.83	72.5	2.2	150	125	163
	182	50.6	25.2		16.43	76	2.0			
	218.5	60.7	12.9		10.37	74	2.2			
GHS125/400	144	40.0	59.5	1450	30.30	77	2.2	150	125	101
	245	68.1	52		45.35	76.5	2.4			
	300	83.3	45		52.15	70.5	3.0			
GHS125/400A	139	38.6	53.5	1450	31.40	64.5	2.2	150	125	181
	236.5	65.7	46		40.04	74	2.4			
	289	80.3	38.5		45.23	67	3.0			
GHS125/400B	133.5	37.1	51.2	1450	29.08	64	2.2	150	125	181
	227.5	63.2	40		35.15	70.5	2.3			
	278.5	77.4	32.5		40.41	61	2.8			
GHS125/500	150	41.7	83.5	1450	54.14	63	2.3	150	125	390
	250	69.4	78		75.86	70	2.5			
	300	83.3	72		90.50	65	2.6			
GHS125/500A	135	37.5	78.5	1450	48.10	60	1.8	150	125	390
	225	62.5	75		62.10	74	2.1			
	270	75.0	71		68.69	76	2.5			
GHS125/500B	120	33.3	75	1450	45.39	54	1.6	150	125	390
	200	55.6	72		58.53	67	2.0			
	240	66.7	69		64.43	70	2.4			
GHS125/500C	90	25.0	67	1450	32.84	50	1.6	150	125	309
	150	41.7	65.5		41.81	64	2.0			
	180	50.0	62		45.36	67	2.4			
GHS150/200	216	60.0	14.4	1450	12.10	70	3.0	200	150	156
	360	100.0	12.2		14.95	80	3.5			
	424.8	118.0	10.3		15.47	77	4.0			
GHS150/200A	172.8	48.0	13.4	1450	9.27	68	3.1	200	150	156
	288	80.0	12		12.07	78	3.8			
	345.6	96.0	10.5		13.00	76	4.2			
GHS150/260	194	53.9	23.5	1450	16.55	75	2.7	200	150	148
	324	90.0	20.5		22.06	82	3.0			
	414	115.0	16		26.53	68	3.3			
GHS150/260A	180	50.0	21.2	1450	14.43	72	2.6	200	150	148
	300	83.3	19		19.53	79.5	2.9			
	388.8	108.0	14.5		22.58	68	3.3			
GHS150/260B	162	45.0	19	1450	11.33	74	2.6	200	150	148
	270	75.0	16.5		15.36	79	2.8			
	342	95.0	12.5		17.12	68	3.2			
GHS150/320	230	63.9	36.5	1450	30.89	74	2.8	200	150	170
	370	102.8	33		41.05	81	3.2			
	445	123.6	28.5		46.05	75	3.6			



## 性能参数 Performance parameters

(4P)

泵型号 Pump model	流量 capacity		扬程 head h (m)	转速 speed n (r/min)	轴功率 shaft power (kW)	效率 eff. η (%)	必需汽 蚀余量 npshr (m)	泵口径 pump (mm)		泵重量 weight (kg)
	m <sup>3</sup> /h	l/s						吸入 suction	排出 discharge	
GHS150/320A	220	61.1	33.4	1450	27.79	72	2.8	200	150	170
	354	98.3	29.3		35.76	79	3.1			
	426	118.3	25		39.19	74	3.5			
GHS150/320B	209.5	58.2	30	1450	24.11	71	2.8	200	150	170
	337.5	93.8	26		31.04	77	3			
	405.5	112.6	21.9		33.13	73	3.3			
GHS150/400	240	66.7	58	1450	50.54	75	2.8	200	150	209
	385	106.9	53.5		66.78	84	3.2			
	460	127.8	49		73.96	83	3.6			
GHS150/400A	232	64.4	52	1450	45.63	72	2.8	200	150	209
	372	103.3	47.5		61.69	78	3.2			
	444	123.3	42.5		66.74	77	3.6			
GHS150/400B	223	61.9	48	1450	41.64	70	2.8	200	150	209
	357.5	99.3	43.5		55.72	76	3.1			
	427.5	118.8	39		61.36	74	3.5			
GHS150/500	300	83.3	86.5	1450	89.5	79	3.1	200	150	410
	500	138.9	77.5		125.6	84	3.5			
	600	166.7	69		139.2	81	3.8			
GHS150/500A	270	75	79.5	1450	79.0	74	3.0	200	150	410
	450	125.0	72		110.3	80	3.4			
	540	150.0	63		120.3	77	3.6			
GHS150/500B	240	66.7	75.5	1450	71.5	69	2.8	200	150	410
	400	111.1	70		96.5	79	3.2			
	480	133.3	65		108.9	78	3.5			
GHS150/500C	210	58.3	68	1450	58.0	67	2.6	200	150	410
	350	97.2	63		78.0	77	3.0			
	420	116.7	60.5		91.1	76	3.3			
GHS200/260	259.2	72.0	19.5	1450	18.86	73	3.0	200	150	256
	432	120.0	15.2		21.81	82	3.2			
	518.4	144.0	12		22.89	74	3.3			
GHS200/260A	248.4	69.0	18	1450	16.91	72	2.9	200	150	256
	414	115.0	14		19.49	81	3.1			
	496.8	138.0	10.5		19.73	72	3.2			
GHS200/260B	237.6	66.0	15	1450	13.87	70	2.8	200	150	256
	396	110.0	12		16.18	80	3.0			
	475.2	132.0	9.7		17.93	70	3.1			
GHS200/320	345	95.8	35	1450	45.36	72.5	3.2	250	200	310
	575	159.7	30		56.26	83.5	3.3			
	690	191.7	25.5		60.27	79.5	3.4			
GHS200/320A	324	90.0	30	1450	37.28	71	3.1	250	200	310
	540	150.0	25.5		45.18	83	3.2			
	648	180.0	21		47.51	78	3.3			
GHS200/320B	302.4	84.0	26.5	1450	32.33	67.5	3.0	250	200	310
	504	140.0	22		36.82	82	3.1			
	604.8	168.0	18.3		38.89	77.5	3.2			
GHS200/400	390	108.3	59.5	1450	85.40	74	3.0	250	200	345
	650	180.6	53.5		112.74	84	3.8			
	780	216.7	48.5		125.64	82	4.5			
GHS200/400A	360	100.0	52.5	1450	73.53	70	2.9	250	200	345
	600	166.7	46.5		93.80	81	3.6			
	720	200.0	41.5		101.72	80	4.4			
GHS200/400B	330	91.7	41.5	1450	54.05	69	2.8	250	200	345
	550	152.8	36		66.57	81	3.5			
	660	183.3	31		71.43	78	4.2			
GHS200/500	330	91.7	90	1450	118.94	68	3.2	250	200	510
	550	152.8	87		160.88	81	4.0			
	660	183.3	84.5		189.85	80	4.8			
GHS200/500A	300	83.3	82.5	1450	97.68	69	3.0	250	200	510
	500	138.9	80		132.04	82.5	3.8			
	600	166.7	77.5		150.75	84	4.5			
GHS200/500B	270	75.0	73	1450	85.20	63	2.8	250	200	510
	450	125.0	71.5		112.34	78	3.6			
	540	150.0	69		126.84	80	4.2			
GHS250/320	522	145.0	32	1450	65.93	69	3.0	300	250	375
	870	241.7	27.5		78.03	83.5	4.8			
	1044	290.0	24		83.21	82	6.5			
GHS250/320A	480	133.3	29.5	1450	61.21	63	2.8	300	250	375
	800	222.2	25.5		67.75	82	4.5			
	960	266.7	22.5		70.45	83.5	6.2			





## 性能参数 Performance parameters

(4P)

泵型号 Pump model	流量 capacity		扬程 head h (m)	转速 speed n (r/min)	轴功率 shaft power (kW)	效率 eff. η (%)	必需汽 蚀余量 npshr (m)	泵口径 pump (mm)		泵重量 weight (kg)
	m <sup>3</sup> /h	l/s						吸入 suction	排出 discharge	
GHS250/320B	450	125.0	28	1450	55.34	62	2.5	300	250	375
	750	208.3	24.5		61.78	81	4.2			
	900	250.0	22		65.76	82	6.0			
GHS250/320C	432	120.0	23.5	1450	45.32	61	2.4	300	250	375
	720	200.0	20		49.02	80	4.0			
	864	240.0	17.5		54.18	76	5.8			
GHS250/400	550	152.8	56.5	1450	112.09	75.5	3.0	300	250	455
	760	211.1	54		131.49	85	3.5			
	950	263.9	48.5		151.18	83	4.5			
GHS250/400A	360	100.0	45	1450	71.16	62	2.6	300	250	455
	600	166.7	43		87.83	80	3.2			
	720	200.0	40.5		95.68	83	4.2			
GHS250/400B	300	83.3	35	1450	51.52	55.5	2.3	300	250	455
	500	138.9	33		59.91	75	3.0			
	600	166.7	31		64.12	79	4.0			
GHS250/500	534	148.3	85.5	1450	177.63	70	3.0	300	250	630
	890	247.2	80		236.46	82	5.0			
	1068	296.7	74		265.71	81	7.0			
GHS250/500A	480	133.3	76	1450	148.28	67	2.8	300	250	630
	800	222.2	70.5		191.99	80	4.6			
	960	266.7	65.5		214.05	80	6.7			
GHS250/500B	450	125.0	68	1450	128.21	65	2.6	300	250	630
	750	208.3	63		163.92	78.5	4.4			
	900	250.0	58.4		181.19	79	6.5			
GHS300/400	831.6	231.0	52	1450	168.24	70	5.0	350	300	700
	1386	385.0	46.5		204.09	86	7.0			
	1663.2	462.0	42		217.41	87.5	8.0			
GHS300/400A	720	200.0	45	1450	135.75	65	4.8	350	300	700
	1200	333.3	40.5		163.40	81	6.5			
	1440	400.0	37		176.95	82	7.5			
GHS300/400B	594	165.0	38.5	1450	114.27	54.5	4.5	350	300	700
	990	275.0	35		127.52	74	6.0			
	1188	330.0	32.5		133.10	79	7.0			

※泵型号列表中加入字母“G”表示为此泵结构经过改进，泵轴直径及外形安装尺寸不同，性能无变化。

※ If a model is added with "G", it means the pump structure is improved. The pump shaft diameters, shapes and installation dimensions are different, but the performances are the same.

## 订货参数

- 泵的型号
- 流量Q
- 扬程H
- 进口压力
- 泵主要零件及密封环材质
- 输送介质及介质温度
- 轴封型式：填料密封或机械密封
- 润滑方式：脂润滑 / 油润滑（依据悬架设计决定）
- 电机型号：电压、功率、防护等级、绝缘等级等。
- 注：用户订货不受样本技术数据表格中的参数限制，所列参数只是特殊典型参数，供用户参考，本公司根据用户设计所需参数提供产品。

## Order parameters

- Pump Model
- Flow Q
- Delivery Lift H
- Inlet Pressure
- Main Pump Parts and Seal Ring Materials
- Conveyance Medium and Medium Temperature
- Shaft Gland Type: Stuffing Seal or Mechanical Seal
- Lubrication Method: Grease Lubrication / Oil Lubrication (in accordance with suspension fork designs)
- Motor Model: Voltage, Power, Protection Grade and Insulation Grade
- Note: the customer orders are not confined by the parameters in the sample technical data sheet. All listed parameters are just specific typical parameters for the customer's reference



## 泵头外形尺寸 Outline dimensions

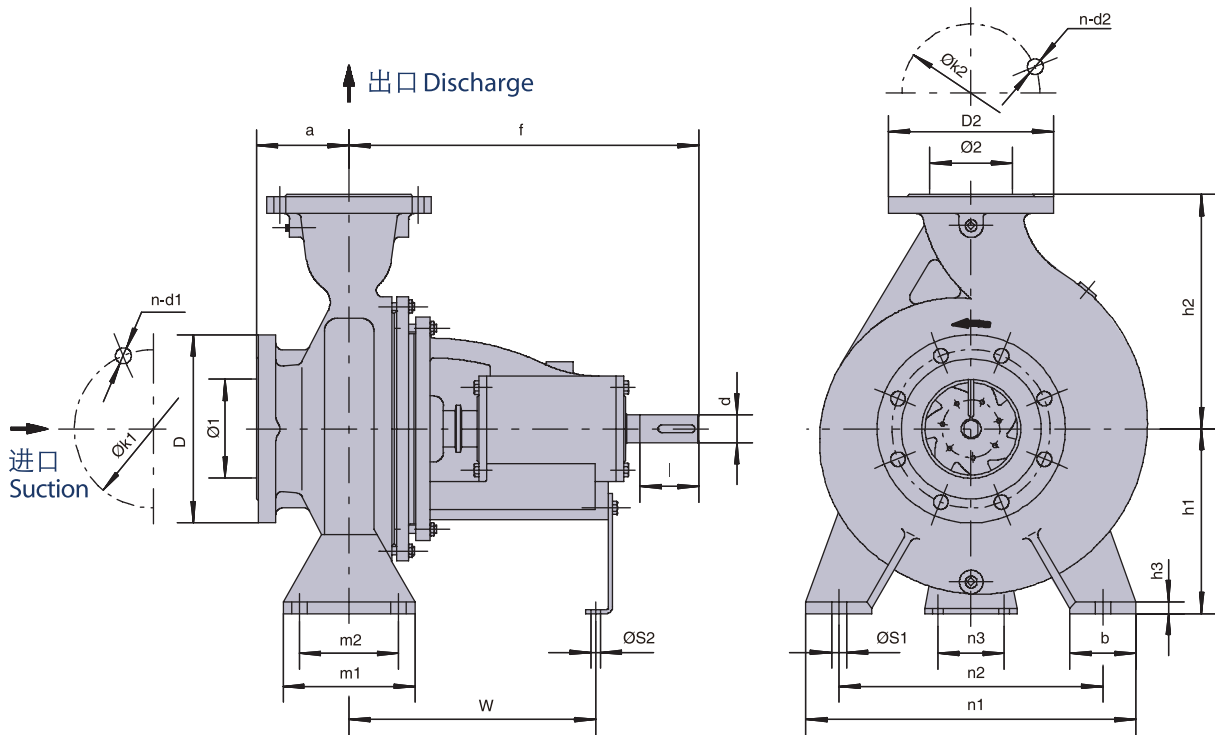

法兰连接尺寸 Flange connection dimensions

$\varnothing 1$ 、 $\varnothing 2$	32	40	50	65	80	100	125	150	200	250	300	350	400
$\varnothing K1$ 、 $\varnothing K2$	100	110	125	145	160	180	210	240	295	355	410	470	525
$n-d1$ 、 $n-d2$	4- $\varnothing 18$	4- $\varnothing 18$	4- $\varnothing 18$	4- $\varnothing 18$	8- $\varnothing 18$	8- $\varnothing 18$	8- $\varnothing 18$	8- $\varnothing 22$	12- $\varnothing 22$	12- $\varnothing 26$	12- $\varnothing 26$	16- $\varnothing 26$	16- $\varnothing 30$
$D1$ 、 $D2$	140	150	165	185	200	220	250	285	340	405	460	520	580

法兰连接尺寸符合国际标准ISO2084 PN16

Flange connection dimensions are accordance with International standard ISO2084 PN16



## 外形及安装尺寸 Installation dimensions

泵规格 Pump type	轴径 diameter of shaft	进口 suction Ø1	出口 discharge Ø2	泵尺寸 pump dimensions				泵脚尺寸 pump foot dimensions										轴端尺寸 (mm) Shaft end dimensions (mm)	
				a	f	h1	h2	b	m1	m2	n1	n2	n3	h3	Øs1	Øs2	w	d	l
GHS32/130	25	Ø50	Ø32	80	360	112	140	50	100	70	190	140	110	14	14	14	267	24	50
GHS32/160	25	Ø50	Ø32	80	360	132	160	50	100	70	240	190	110	14	14	14	267	24	50
GHS32/200	25	Ø50	Ø32	80	360	160	180	50	100	70	240	190	110	14	14	14	267	24	50
GHS32/260	25	Ø50	Ø32	100	360	180	225	65	125	95	320	250	110	14	14	14	267	24	50
GHS40/130	25	Ø65	Ø40	80	360	112	140	50	100	70	210	160	110	14	14	14	267	24	50
GHS40/160	25	Ø65	Ø40	80	360	132	160	50	100	70	240	190	110	14	14	14	267	24	50
GHS40/200	25	Ø65	Ø40	100	360	160	180	50	100	70	265	212	110	14	14	14	267	24	50
GHS40/260	25	Ø65	Ø40	100	360	180	225	65	125	95	320	250	110	14	14	14	267	24	50
GHS40/320H	35	Ø65	Ø40	125	470	200	225	65	125	95	345	280	110	14	14	14	342	32	80
GHS50/130	25	Ø65	Ø50	100	360	132	160	50	100	70	240	190	110	14	14	14	267	24	50
GHS50/160	25	Ø65	Ø50	100	360	160	180	50	100	70	265	212	110	14	14	14	267	24	50
GHS50/200	25	Ø65	Ø50	100	360	160	200	50	100	70	265	212	110	14	14	14	267	24	50
GHS50/260	25	Ø65	Ø50	100	360	180	225	65	125	95	320	250	110	14	14	14	267	24	50
GHS50/260G	35A	Ø65	Ø50	100	454	180	225	65	125	95	320	250	110	14	14	14	327	32	80
GHS50/320H	35	Ø65	Ø50	125	470	225	280	65	125	95	345	280	110	16	14	14	342	32	80
GHS65/130	25	Ø80	Ø65	100	360	160	180	65	125	95	280	212	110	14	14	14	267	24	50
GHS65/160	25	Ø80	Ø65	100	360	160	200	65	125	95	280	212	110	14	14	14	267	24	50
GHS65/200	25	Ø80	Ø65	100	360	180	225	65	125	95	320	250	110	14	14	14	267	24	50
GHS65/200G	35A	Ø80	Ø65	100	454	180	225	65	125	95	320	250	110	14	14	14	328	32	80
GHS65/260	35	Ø80	Ø65	100	470	200	250	80	160	120	360	280	110	16	18	14	342	32	80
GHS65/320H	35	Ø80	Ø65	125	470	225	280	80	160	120	400	315	110	16	18	14	342	32	80
GHS80/160	25	Ø100	Ø80	125	360	180	225	65	125	95	320	250	110	14	14	14	267	24	50
GHS80/160H	35A	Ø100	Ø80	125	454	180	225	65	125	95	320	250	110	14	14	14	326	32	80
GHS80/200	35	Ø100	Ø80	125	470	180	250	65	125	95	345	280	110	14	14	14	342	32	80
GHS80/260	35	Ø100	Ø80	125	470	200	280	80	160	120	400	315	110	16	18	14	342	32	80
GHS80/320H	35	Ø100	Ø80	125	470	250	315	80	160	120	400	315	110	16	18	14	342	32	80
GHS80/400	45	Ø100	Ø80	125	520	280	355	85	160	120	400	355	110	16	18	14	370	42	110
GHS100/200	35	Ø125	Ø100	125	470	200	280	80	160	120	360	280	110	16	18	14	342	32	80
GHS100/260	35	Ø125	Ø100	140	470	225	280	80	160	120	400	315	110	16	18	14	342	32	80
GHS100/320	35	Ø125	Ø100	140	470	250	315	80	160	120	400	315	110	16	18	14	342	32	80
GHS100/400	45	Ø125	Ø100	140	530	280	355	100	200	150	500	400	110	18	23	14	370	42	110
GHS125/200	35	Ø150	Ø125	140	470	250	315	80	160	120	400	315	110	16	18	14	342	32	80
GHS125/260	35	Ø150	Ø125	140	470	250	355	80	160	120	400	315	110	16	18	14	342	32	80
GHS125/320	45	Ø150	Ø125	140	530	280	355	100	200	150	500	400	110	18	23	14	370	42	110
GHS125/400	45	Ø150	Ø125	140	530	315	400	100	200	150	500	400	110	18	23	14	370	42	110
GHS125/500	60	Ø150	Ø125	160	670	375	500	120	200	150	550	450	140	25	23	14	511	55	110
GHS150/200	35G	Ø200	Ø150	160	495	280	400	100	200	150	550	450	110	20	23	14	342	32	80
GHS150/260	45	Ø200	Ø150	160	530	250	355	100	200	150	450	350	110	18	23	14	370	42	110
GHS150/320	45	Ø200	Ø150	160	530	280	400	100	200	150	550	450	110	18	23	14	370	42	110
GHS150/400	45	Ø200	Ø150	160	530	315	450	100	200	150	550	450	110	18	23	14	370	42	110
GHS150/500	60	Ø200	Ø150	180	670	375	500	120	200	150	550	450	140	25	23	14	511	55	110
GHS200/260	45	Ø250	Ø200	180	550	280	400	100	200	150	550	450	110	25	27	14	389	42	110
GHS200/320	55	Ø250	Ø200	200	670	355	450	100	200	150	550	450	110	20	23	14	511	48	110
GHS200/400	55	Ø250	Ø200	200	670	355	500	120	200	150	550	450	110	20	23	14	511	48	110
GHS200/500	60	Ø250	Ø200	210	675	400	500	160	300	240	720	600	140	30	27	14	511	55	110
GHS250/320	55	Ø300	Ø250	200	670	355	525	100	250	175	600	500	110	24	23	14	511	48	110
GHS250/400	60	Ø300	Ø250	250	670	400	500	120	300	250	710	600	110	25	23	14	511	55	110
GHS250/500	75	Ø300	Ø250	240	875	425	545	160	300	200	720	600	140	30	27	19	625	70	140
GHS300/400	75	Ø350	Ø300	280	875	500	600	150	300	200	800	660	140	40	27	19	625	70	140



# Welcome to ask for the following product catalogue



## Pump series

- Submersible pump series
- On land pump series
- Special pump series
- Fire fighting pump series



## Mixing and flow Propeller series

- Mixer series
- Flow propeller series



## Aerating oxygen Inputing series

- Aerator series
- Disc diffuser series
- Diffuser series



## Blower series

- Three-lobe roots blower series
- Pressure boost roots blower



## Sludge treatment equipment and others

- Solid liquid separation series
- Dissolving equipment
- Conveying equipment



本型录内容如有变更，恕不另行通知。  
We reserve the right to change content without notice.